

# UNIVERSITY OF BENIN



*Benin City, Nigeria*

## *Training Course 1*

---

# **WATER SUPPLY AND ENVIRONMENTAL ENGINEERING**

Module 1: Legal and Institutional Framework for Water Supply and Environmental Engineering

Module 2: Urban Water Supply System

Module 3: Monitoring and Adaptive Management of Water Supply System

Module 4: Waste Water Management

Module 5: Wetlands and Estuarine

# **Module I: Legal and Institutional Framework for Water Supply and Environmental Engineering**

## **Contents**

1. Status of Water Supply in Nigeria
2. Constraints of Water Supply
3. Legal Aspects of Water Supply
4. Economic Aspects of Water Supply
5. Inclusive and sustainable development principles for water supply

### **1. Status of Water Supply in Nigeria**

Water is the most basic service required for the sustenance of both human life and general ecosystem provisioning, regulating, supporting and cultural services. That is why it is commonly said that water is life and needs to be available in sufficient quantity and quality for human, plant, animal and ecosystems functioning. Although water covers about 70 percent of the earth's surface, only 2.5 percent of the earth's water is regarded as fresh water and the percentage of portable or drinkable water is even far less (Raymond and Streeter 2013). More so, the demand for water is continuously on the increase and this phenomenon is traceable to drivers such as the ever growing human population and the attendant increase in consumption per person, water scarcity due to extreme weather events and variability related to climate change, power dynamics and legal factors affecting accessibility and the high cost of sourcing, operating and maintaining water supply services/infrastructure in some cases. Thus, a larger majority of earth's human inhabitants suffer from water poverty; 2.1 billion people or roughly 3 in 10 people worldwide, lack access to safe, readily available water for personal and domestic uses at home (World Health Organization 2017).

With an estimated 267 billion cubic metres of surface water and 92 billion cubic metres of ground water and over 200 dams with a total storage capacity of about 34 billion cubic metres, Nigeria has relatively rich water supply for human consumption. Nonetheless, it is important to note that some states in the northern part of the country face more serious water scarcity than those in the southern part (see for instance Ifan 2002). Overall, Nigeria ranks amongst the countries with the lowest level of potable water supply in the world. There is an increasing demand for safe drinking water for human consumption due to factors such as: population growth, urbanization, industrialization, agriculture and extreme weather events and variability induced by climate change that may directly or indirectly affect water infrastructure and availability. The main sources of water supply for human consumption in Nigeria to include pipe-borne water; boreholes (including solar powered, machine and hand pumps); wells (either shallow or deep); surface waters (such as lakes, rivers, ponds and irrigation sources) and other sources such as rain water, vendors who sell through carts, trucks and tankers. For instance, Adekunle and Ozabor (2016) reported based on a study which they conducted in Owah-Abbi, Delta state, that 42.6 percent of their study population depend on water provided by government, 20.2 percent depend on community provision, while individuals provide 10.6 percent, and water vendors, tanker drivers, river and rainfall account for the balance 26 percent consumed by the

study's population. The level of coverage of water supply services is abysmally low especially in the rural areas. While the rural areas of Nigeria accommodate at least 50 percent of the total population of the country, between 60 percent and 65 percent of the population do not have access to safe drinking water (Enefiok and Ekong 2014). A more recent report from the United Nations Children's Fund indicates the level of deterioration of access as it indicates that currently there are only 26.5% of Nigerians who use improved drinking water sources and sanitation facilities that are safe from contamination (UNICEF 2018).

Attempts by the federal, state and local governments to ensure adequate water supply to meet the ever growing demand have fallen drastically short of required target. As a result, the end users often purchase water at very expensive rates from private vendors over and there is at best a weak regulatory framework for ensuring the quality of the water supply services. Access to water and sanitation is critical for the development of key sectors such as health, education, environment and agriculture, to name a few. The poor level of access to water and sanitation in Nigeria today is one of the main contributing factors to high morbidity and mortality rates among children under five, increased vulnerability to diarrhoeal and other water-borne diseases, absenteeism among school children especially girls who are responsible for fetching water from locations that are far away from their homes, malnutrition and stunting among children, economic losses either due to water-borne diseases or time spent fetching water and conflicts over access and allocation of water resources.

## **2. Constraints of Water Supply**

Several factors constrain adequate supply of water in Nigeria. They include the following:

- i. Poor funding
- ii. Poor management culture (maintenance)
- iii. Theft and vandalization
- iv. Corruption
- v. Political interference
- vi. Poor power supply

### **i. Poor funding**

The level of public funding for water supply is very low in Nigeria and has steadily declined as a percentage of the annual national budget (Egbinola, 2017). Even the funds that are earmarked in the government budgets are hardly released for the execution of the relevant water projects, and the released funds are often diverted to other uses (Oluwabunmi 2013). In addition, bureaucratic red-tapism or protocols in the Ministry of Water Resources and other related agencies create excessive delays in the execution of water projects. Consequently, the burden of financing water supply services falls on the households despite the high level of poverty in the country.

### **ii. Poor management (maintenance) culture**

Many water supply systems in Nigeria exhibit high levels of deterioration and the existing capacities are under-utilized due to poor maintenance and lack of improvements in the technology. Rather than being proactive in the management of water infrastructure by sending early warning signals to the presiding Ministry, managers of water infrastructure wait until a vital component of the dam or borehole breaks down. This often exacerbates the already precarious water supply problem in the locality.

### **iii. Theft and vandalism**

Materials and machineries procured for the purpose of providing water to the residents of designated localities are in most cases out-rightly stolen or vandalized by those who are supposed to utilize them. In most cases when the vandalized equipment are replaced, such workmen are compensated by the contractors.

### **iv. Corruption**

Collusion between government officials and community heads usually undermine the productivity of water projects. The capacity of the pumps or storage facilities are stepped down to free some funds for the contractors, managers and community heads to share. The reduction in the capacities of these equipment undermines the water supply to the community or communities under reference.

### **v. Political interference**

In Nigeria, communities requiring potable water are prone to making representation to government through the leaders of the communities. When such pressure groups succeed, the location of the project becomes highly dependent on major political power struggle. Influential politicians from certain quarters in such communities often influence the location of the project or projects in their communities rather than centrally located to the advantage of all concerned. Others are forced to cover distances to get potable water for domestic consumption.

### **vi. Epileptic power supply**

In the absence of hand-pumps, machine pumps or solar powered pumps, both rural and urban communities in Nigeria suffer grossly from the lack of electricity and other alternative forms of stable power supply for the operation of their water pumps. When this problem persists, residents resort to the consumption of low quality water or purchase potable water at very costly rates.

## **3. Legal and Regulatory Aspects of Water Supply**

Water regulation cuts across various ministries, departments, agencies and institutions of government in Nigeria, including the Ministry of Water Resources at the federal level and within the various states, the National Water Resources Institute and the River Basin Development Authorities. The Federal Ministry of Water Resources is responsible for policy formulation and coordination within the water sector; the National Water Resources Institute conducts research and capacity building; the River Basin Development Authorities are responsible for providing water to communities for domestic, agricultural and industrial uses. In addition, other Ministries in charge of health, environment, education and power, works and housing also necessarily interface with the water sector in the course of delivering their respective mandates. The distribution of responsibilities among the various government entities has largely been reactive and motivated by either environmental or political factors (Handidu 1990). As a result, the plurality of actors in the water sector has led to fragmentation and incoherence in the water governance process.

The main law for the regulation of the water sector in Nigeria is the Water Resources Act 1993. The Water Resources Act vests the control of surface water affecting more than one state of the federation in the federal government. It recognises a variety of formal and informal legal regimes, especially customary and statutory water rights; the Water Resources Act provides that:

“any person who has a statutory or customary right of occupancy to any land, may take and use water from the underground water source or if abutting on the bank of any water course, from that water course, without charge for domestic purposes, for watering livestock and for personal irrigation schemes.” The Water Resources Act prescribes penalties for the contravention of its provisions. Remarkably, it is doubtful that the severity of the penalties, especially the monetary value of the fines, can effectively act as a deterrent in the contemporary Nigerian society. For instance, the Water Resources Act in section 18 provides that: “Any person who contravenes or fails to comply with any provisions of this Decree, or any regulation, made there under commits an offense and is liable upon conviction to a fine not exceeding N 2,000, or to a term of imprisonment not exceeding six months, or to both such fine and imprisonment and, in the case of a continuing offense, to an additional fine not exceeding N 100 for every day, or part of a day, that the offense continues”.

Hence, water supply in Nigeria is subject to both customary and statutory water rights as indicated in the Water Resources Act, as well as human rights standards for drinking water and the general principles of contracts and dispute resolution discussed below.

### ***Statutory water rights***

The Water Resources Act 1993 vests the Federal Government of Nigeria with the right to the use and control all surface and groundwater and all water in any water-course affecting more than one State, for the purpose of promoting the planning, development and use of the country’s water resources; coordinating the distribution, use and management of water resources; and ensuring the application of appropriate standards for the investigation, use, control, protection, management and administration of water resources. Furthermore, the Act empowers any person: (i) to take water without charge for domestic purpose or for watering livestock from any water course to which the public has free access; (ii) to use water for the purpose of fishing or for navigation to the extent that such use is not inconsistent with any other law for the time being in force; or (iii) who, has a statutory or customary right of occupancy to any land, to take and use water from the underground water source or if abutting on the bank of any water course, from that water course, without charge for domestic purposes, for watering livestock and for personal irrigation schemes.

The water rights stipulated under the Water Resources Act are however subject to the authority of the Minister for Water Resources as the Act empowers the Minister to control the use of groundwater, including through determining the time, places and manner for taking or using water; fixing the amount of water that may be collected during emergencies; prohibiting the water collection or use for health reasons; regulating the construction and operation of boreholes; and revoking water rights in the public interest. The Act stipulates the corresponding duties on the Minister in relation to making proper provision for adequate water supplies for domestic uses like drinking, bathing and cooking, non-domestic uses such as commercial purposes, the watering of animals, irrigation, agricultural purposes as well as the generation of hydro-electric energy for navigation, fisheries and recreation.

### ***Human right to water***

General Comment No. 15 of the UN Committee on Economic, Social and Cultural Rights that was adopted in 2002 expressly states that: “[T]he human right to water is indispensable for leading a life in human dignity. It is a prerequisite for the realization of other human rights”. The

General Comment also defined the right to water as the right of everyone to sufficient, safe, acceptable and physically accessible and affordable water supply for personal and domestic uses. This General Comment has formed a strong legal basis for the evolution of the human right to water and later the human right to sanitation as independent rights in international human rights law. Subsequently, in 2010, the United Nations General Assembly explicitly recognised the human right to water and sanitation, stating that clean drinking water and sanitation are essential to the realisation of all human rights. The Resolution calls upon States and international organisations to provide financial resources, capacity-building and technology transfer to assist countries, especially the developing countries, to provide safe, clean, accessible and affordable drinking water and sanitation for all.

In turn, an increasing number of national constitutions in different parts of the world recognise sufficient, safe, acceptable, physically accessible and affordable water supply as a human right. Even in the absence of express recognition of the right in the constitution, the courts in countries such as India, have proactively implied the existence of a human right to water from express legal rights such as the right to life in particular. This is in recognition of the indispensable nature of water for human survival, wellbeing and development. However, the Constitution of the Federal Republic of Nigeria 1999 does not expressly guarantee the right to water (Obani 2018). Nonetheless, Nigeria has ratified international conventions like the African Charter on Human and Peoples Rights which guarantee civil, political, economic, social and cultural rights that are inextricably linked to the right to water. For instance, the right to water is essential for the realisation of the right to health, adequate standard of living and work that are contained. As such, the government owes a legal and moral duty to ensure progressive realisation of universal access to safe drinking water for its citizens. There is no decided case on the human right to water in Nigeria yet though.

### ***Contract management and dispute settlement***

Service level agreements are commonly used in the water sector to define the level of service expected of a supplier at a defined price, subject to the standards for water supply specified in the relevant water laws. Service indicators that are commonly included in the service level agreements include coverage of the service area, service hours, water quality, unjustified disconnections, billing for services and client contacts. Depending on the specifications in the law, regulators, households and end users may be entitled to seek judicial or administrative remedies against the service provider for any violation of the agreed water supply service levels. Where the dispute arises from statutory water rights or a formal contract for water supply services, then the parties can approach the Magistrate or High Courts in their locality for a determination of their respective rights and responsibilities.

In relation to disputes over customary rights to water, there are two main dispute settlement options. These include: (a) indigenous adjudication systems involving presided over by the leadership of the community; and (b) judicial proceedings instituted before customary courts in the locality where the dispute arose. The informal sector (e.g. small water vendors, households and individuals who supply water from their boreholes to other members of the public) which is the main source of water supply services for households and individuals in both urban and rural areas are generally not subject to formal contract terms and service agreements as previously discussed. Nonetheless, where a person accepts payment or any other consideration for the

supply of water services, irrespective of the formal or informal nature of the agreement, the receiver is bound to supply the services as agreed. Otherwise, the party who offered the consideration can pursue legal remedies for damages for breach of contract terms and where relevant the receiver may also be criminally liable for fraud.

#### **4. Economic Aspects of Water Supply**

As Bamimore, Farayola and Amao (2002) put it – water supply services are unreliable and of low quality and are not sustainable because of the difficulties in management, operation, pricing and failure to recover costs. For efficiency in the provision of access to clean water for domestic use in Nigeria, there is the need for appreciable investment in water supply infrastructure and a restructuring of the operation and maintenance culture of water projects. This will obviously require substantial financing efforts from various stakeholders, including the national and sub-national governments, the private sector, households and individual end users, non-governmental organisations, community based organisations and international development agencies. This section therefore considers the alternative sources of water supply finance in Nigeria and the options for water pricing (types of tariffs).

##### ***Sources of Financing Water Supply in Nigeria***

The major sources of financing water projects in Nigeria are Federal, State and Local government financing; internally generated revenue by state water agencies; and commercial loans and development assistance from international agencies.

##### **i. Government Financing**

The Federal government through the Ministry of Water Resources and River Basin Authorities provide funds for the execution and sustenance of water projects in the country. Similarly, the states and local councils also locate funds in their annual budgets for the running of various water projects in their domain. Remarkably, a huge percentage of investment in water schemes by the federal government is directed at industrial and irrigation programmes and not for domestic consumption alone. The states provide about 25 percent of capital investment for water supply to cover the treatment and distribution of water for domestic use in urban centres. Investments in water schemes by the local governments are usually very small and restricted to rural and semi-urban areas.

##### **ii. Internally Generated Revenue by State Water Agencies**

Internally generated revenue by state water agencies and boards remain an important source of funds for the financing of water projects in Nigeria. But, this source is bedeviled by the inability of state governments to introduce full cost recovery system to support internal revenue generation on a sustainable basis to defray operation and maintenance costs. There is also lack of accountability in relation to the amount of revenue generated from water supply services and how the revenue of disbursed or reinvested for service improvements and development of the sector.

##### **iii. Commercial Loans and International Development Assistance**

The Federal government in most cases floats treasury bills, bonds and development loan stocks to secure funds for development from commercial banks, other financial institutions and individuals for the purpose of executing water schemes and other associated developmental

projects in the country. In addition, loans are also secured from external sources for these projects. The state governments through the intervention of the federal government could access loans from the World Bank, the African Development Bank, the U.S based Department for Internal Development (DFID) and several other international sources for the purpose of enhancing potable water supply in their jurisdictions.

#### **iv. Households and Others**

Households and individual end users end up bearing most of, if not all in a majority of cases, the financial costs of the infrastructure, maintenance and operations for their water supply services. As a result, the quality of the water and the level of maintenance heavily depend on the (technical and financial) capability of the households and individuals. Furthermore, the private contributions from households and individuals users are in most cases restricted to their localities and poorly coordinated to add to up systemic improvements in the national water supply infrastructure and services.

#### ***Water Tariffs and Payment Structure***

Water is an economic good and based on macroeconomics, the most approximate determinant of water tariffs is its economic value. This value is mostly determined by the interaction of the forces of demand for and supply of water. There are four different types of tariffs commonly adopted in the water sector, including: (a) uniform flat rate; (b) single-block rate; (c) two-part tariff and (d) rising block tariff. A uniform flat rate tariff means that users are required to pay a flat rate irrespective of the quantity of water they consume. A single-block rate tariff is used to charge a user a fixed rate for each block or unit of water used, as measured by a meter. Two-part tariff includes two different charges; a charge for the quantity of water used and an additional fixed charge to cover costs that are not dependent on the quantity of water consumed. Rising block tariff entails users being charged a minimum price or no cost at all for the first block of water consumed while incremental blocks of water are charged at increasingly higher rates. Tariff structures which involve charging for higher consumption levels promote water conservation but may also work additional hardship on large poor families.

It is quite obvious that the demand for water in Nigeria far outstrips supply and the price of water is expected to be reasonably high. But there are other social and economic considerations which make it necessary to apply pro-poor instruments to make water supply services affordable for the poor who would otherwise be unable to pay the real economic cost of water. According to the World Research Observer (1993), many of the water projects implemented over the last decades in developing countries were considered failures primarily because of the issue of affordability of the tariffs for the local communities. Generally, the poor cannot cope with the tariffs allocated to their locality, in rural and urban areas alike while the middle and upper income classes are better able to cope with the tariff structure. However, the major problem is in the ability of government to devise appropriate means of disaggregating tariffs between rural and urban communities and enforcing collection. According to Akpe (2012), it is estimated that at least 90 percent of the country lacks a clear framework for metering, billing or collection of water payments.

### **5. Inclusive and sustainable development principles for water**



Sustainable development defined as development that meets the needs of the present generation without compromising the ability of future generations to meet their own needs. Inclusive development on the other hand is defined as development that includes marginalized people, sectors and countries in the interest of human well-being and empowerment and environmental sustainability (Gupta, Pouw & Ros-Tonen 2015). Sustainable development has three pillars which are the economic, social and cultural, while inclusive development also has three main components, namely: social inclusiveness, inclusiveness as a relational concept or relational inclusiveness, and inclusiveness in the Anthropocene or ecological inclusiveness. Sustainable development, which essentially requires the integration of environmental, social and economic considerations in development decision making and inclusive development, which essentially requires the empowerment of marginalised populations within the ecological limits offer principles for addressing the pressing human development challenges around the world today. It is therefore unsurprising that the seventeen goals in the Sustainable Development Goals 2030 agenda cut across social, economic and environmental issues. The Sustainable Development Goals agenda includes a dedicated goal to ensure universal access to safe drinking water by 2030, which is a more ambitious goal than the water target under the Millennium Development Goals agenda which was focused on halving the number of persons without access to improved water sources. It is therefore imperative that water supply should not only be designed with the goal of providing access to safe drinking water but that it should contribute to the empowerment of marginalised people without adversely affecting environmental sustainability. This would generally increase the cost of water supply in the long term, compared to simply providing water without recourse to social, economic and environmental sustainability concerns. It is estimated that in order for Nigeria to meet the SDG water goal, it is necessary to triple the national budget for water supply or allocate at least 1.7% of the current gross domestic product to water supply and sanitation services. However, the benefits of safe drinking water supply services far outweigh the costs and cut across key sectors of the economy like health, education, agriculture and security to mention a few.

## **REFERENCES**

- Adekunle, O and Ozabor, F (2016) “Factors Affecting Water Supply in Owah – Abbi, Delta State”. *Open Journal of Social Sciences*, vol. 4, PP 137-146. <http://www.scrip.org/journal/jss>.
- Akpe, A (2012). “President Promises Water – Slashes Budget”. *Business Day Newspaper*, March.
- Bamimore K.M, Farayola C.O and Amao I.O (2012). “Evaluation of Improved Household Water Supply in Akinyele Local Government of Oyo State, Nigeria”.
- Egbinola, C.N (2017). “Trend in Access to Safe Water Supply in Nigeria”. *Journal of Environmental and Earth Science*, vol. 7, No. 8.
- Enefiok, E.I and Ekong, E.D (2014). “Rural Water Supply and Sustainable Development”, 2, 68-73. <http://dx.doi.org/10.12691/ajrd-2-4-2>.
- Gupta, J., Pouw, N., & Ros-Tonen, M. (2015). Towards an Elaborated Theory of Inclusive Development. *European Journal of Development Research*, 27(4), 541-559.
- Ifan, A.B (2002). “The Problem of Water Supply in Mbativ district in Gboko Local Government Area of Benue State, Nigeria. Benue State University, Unpublished.
- Obani, P. (2018). *Strengthening the Human Right to Sanitation as an Instrument for Inclusive Development*. Taylor & Francis (CRC Press/Balkema): Leiden.
- Oluwabunmi, M (2013). “The Challenges of Water Supply Schemes in Nigeria”. <https://www.hydratelife.org/1695-2/>.
- Raymond, T.J and Streeter N (2013). “The Economics of Water Supply”.
- UNICEF, Nigeria: Water, Sanitation and Hygiene (Programme 2018) <https://www.unicef.org/nigeria/water-sanitation-and-hygiene>.
- World Bank Research Observer (1993). “The Demand for Water in Rural Areas: Determinants and Implications and Policy”, vol. 8, No.1, pp. 47-70.
- World Health Organization, 2.1 billion people lack safe drinking water at home, more than twice as many lack safe sanitation (12 July 2017 News Release) <https://www.who.int/news-room/detail/12-07-2017-2-1-billion-people-lack-safe-drinking-water-at-home-more-than-twice-as-many-lack-safe-sanitation>.

## MODULE 2: URBAN WATER SUPPLY SYSTEM

### 2.0: INTRODUCTION

This training course series have been formulated to empower young professionals for enhanced operation and maintenance of water supply and sanitation systems in urban areas.

This module which covers Urban Water Supply System provides insights on basics of the components of water supply system, installation and distribution of water supply systems, estimation and measurement of components of water supply system and drinking water quality control.

### 2.1: Components of Urban Water Supply System

The main components of urban water supply system are as illustrated in Figure 1.

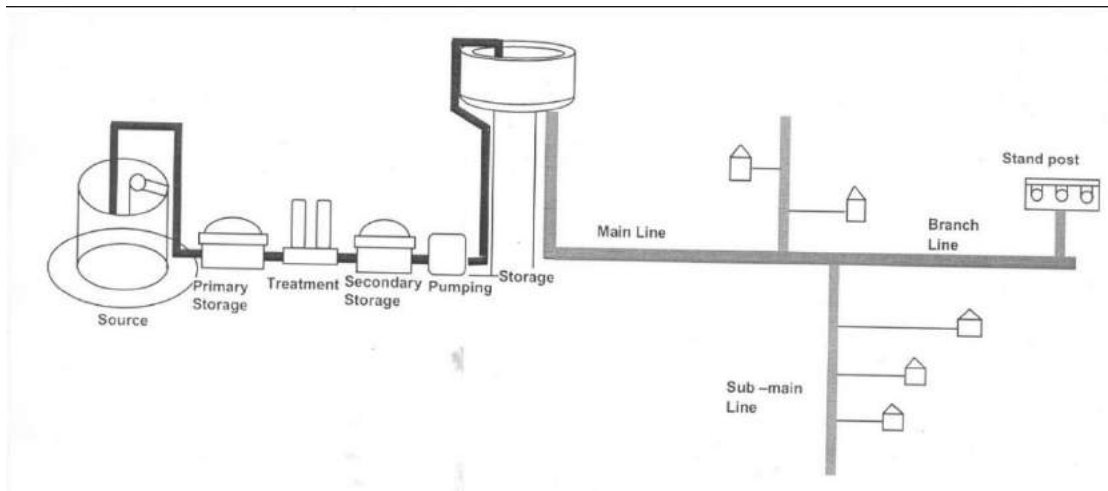

**Figure.2.  
1:**

### Components of Urban Water Supply System

### 2.2: WATER DEMAND

Whenever an engineer is required to design a water supply scheme for a community, or a section of a community, it is important to know the amount of water required (or the water demand) so that source(s) that will be used to meet the demand can be determined.

#### 2.2.1: Factors Affecting Water Use.

The amount and timing of water use in a community is dependent on many factors such as : population size and character; climate cost of water, and other factors . The factors which determine the water requirements of a given community includes:

- (i) Population Characteristics- Water use depends on the socio-economic status of the consumer. The per capita use of water in rural communities lower than that in high brow urban residential areas.
- (ii) Climatic conditions. The requirement for water is higher in warm dry climates than in wet climates for bathing, lawn watering and others.
- (iii) Habit and mode of living
- (iv) Plumbing facilities
- (v) Sewerage
- (vi) Industry- the nature and number of industries located in the locality affects the water use.
- (vii) Water tax - when the cost of water is high, consumers tends to conserve water more and responsive to repair their leaking water facilities.
- (viii) Metering and Charging method: In places where meters (water meters) are installed, less water is consumed in comparison to areas where flat rate is charged. Cost
- (ix) Quality of water.
- (x) Pressure in the distribution system.

### **2.2.2: Estimates of Water Use**

The total water consumed in a community is estimated by adding domestic consumption, fire demand, water required for public use and water utilized by industry. The loss of water due to leaks and other sources are also considered when estimating the total water demand for a community. This may be taken as 10% of the total water demand. The average domestic water requirement of a community is computed based on water consumption per capita per day. In developing countries average water consumption is in the region of 135 *lpcd* and can be as high as 450- 500 *lpcd* in towns in developed countries with good plumbing facilities. The average value of domestic water consumption in some cities in Nigeria is about 120 *lpcd* (Agunwamba, 2000)

**2.3: Components of Municipal Water demand:** The various components of municipal water demand include: (i) Residential (ii) Industrial (iii) Commercial (iv) Public water uses and (v) Unaccounted for system losses.

- (i) **Residential water demand:** This is the component of municipal water supply used in homes for such activities as toilet flushing, cooking, drinking, bathing, washing of plates and clothes, watering lawns and other uses. Average residential water demand may vary from 100 – 450 *lpcd*
- (ii) **Commercial water demand:** This is the water used by commercial establishments such as hotels, office buildings, shopping centres, service stations, air ports. Commercial water demand depends on the type and number commercial establishments in the community. Commercial water demand is about 10 to 20 % of the total water demand.
- (iii) **Industrial water demand:** Industrial water demand is the water used by industries. They are usually very large and hence many industries tend to develop their water supplies; independent of public water supply systems. Only small industries depend on public utilities for their water supply thereby imposing demand on local municipal system.
- (iv) **Public water demand:** This is water that is used in public buildings (such as city halls, jails, schools etc) as well as water used for public services such as fire protection, park irrigation and street washing. Public water use accounts for 5 to 10% of total municipal water demand.
- (v) **Unaccounted system losses and leakage.** In a water supply system there is a certain amount of water that is lost or unaccounted for because of meter under registration and slippage, leaks in mains, faulty meters and unauthorized water connections or outright theft. In municipal supply systems, this may be as high as 10 – 20% of the water demand.

#### **2.4: Water Use Trends**

Projections of community water use are required in distribution system and treatment plant design in addition to information on the timing of the demands. Water demand parameters which are vital in the design and operation of water treatment systems include average day demand, maximum day demand and peak hour demand.

**Average day demand (Add)** refers to the average daily demand over a period of one year and it is computed by dividing the total amount of water produced in a year by 365.

**The maximum day demand (mdd)** is the amount of water required during the day of maximum consumption in a year. It represents the greatest water demand for any 24 hour period and it is a vital parameter used in the analysis of peak capacity of production and treatment facilities. **The peak hour demand** refers to the amount of water required during the maximum consumption hour in a given day and it is an important parameter used to analyze the peak capacity required of the distribution system, elevated reservoir and high service pumps to enable them deliver the peak water demand at the peak hour of the day. The average day, maximum day and peak hour demands are important parameters utilized in planning and design of municipal water supply systems. These variations are often expressed as a ratio of average daily demand. Peaking factors are usually applied to average day demand to obtain maximum day demand and peak hour demand. Typical peaking factors used are :

Maximum day demand = 1.2 - 2 x Average daily demand

Peak hour demand = 2 - 3 x Average daily demand

#### **2.4.1: Variation in Water Consumption**

Water consumption is not constant, it varies yearly, weekly, daily and hourly. During holidays and weekends consumption is high and in a given day, water use is high in the morning hours till close to noon, and early evenings up to 8.00 pm and low at night.

The maximum consumption may be estimated by the following peaking factors (Agunwamba, 2000) :

Peak value /day = 1.2 - 2 times average / day.

Peak value per hour = 2 to 3 times average / day.

- **Seasonal variation:** The demand peaks during dry season, firebreak outs are more rampant in dry season thereby imposing more demand resulting in seasonal variation.
- **Daily variation.** In a given day, water demand varies depending on the activity. People use more water on weekends, public holidays and periods of festivities. Thus increased demands are encountered on such days.
- **Hourly variations** in water use are also encountered. When major household activities are taking place like when people have to prepare food, take their baths, wash plates and

clothes and other required activities at such times as 6.00 am to close to noon and 4.00 pm to 8.00 pm in the evening, daily water requirement is at the peak. During other hours of the day, the water requirement is much smaller. However, in the event of a fire outbreak, large quantity of water is needed to be supplied in a short time to attend to the emergency, hence maximum rate of hourly supply is necessary.

In a well designed water supply system, adequate quantity of water should be available to meet the requirements of the peak demand. In order to cope with all the anticipated fluctuations, supply pipes, service reservoirs and distribution pipes must be of right sizes. If the water supply is by direct pumping, the pumps and distribution system must be adequately designed to meet peak demand. The monthly variation in water demand influences the design of storage reservoirs while the hourly variation in water demand influences the design of pumps and service reservoirs. Provision must be made for certain quantity of water for fire fighting purpose. The quantity of water required for fire fighting is depends on the inflammability and intensity of heat generated by the burning material, contents and type of building.

## **2.5: Fire demand**

Fire demand is an important consideration in the design of municipal water supply system. Design requirements vary from one municipality to another hence design should be in accordance with applicable guidelines and regulations. The annual volumes of water needed for fire fighting are often small but during fire fighting operation, the demand is usually large and may therefore be governing consideration in the design of distribution system, distribution storage and the required pumping equipment.

Industrial areas or areas that are thickly populated are usually susceptible to fire hazards, which may lead to serious losses if not controlled effectively. Fire fighting requires sufficient quantity of water for extinguishing fires when an outbreak occurs. The quantity of water required for extinguishing fires should be readily available and kept always stored in reservoirs. In the design of public water systems the rate of fire demand may sometimes be determined as a function of population using empirical formulae such as the Kuichling and National Board for Fire Underwriters (NBFU) formulae .

**(i) Kuichling formula** is given as :

$$Q = 3182\sqrt{P}$$

Where Q = amount of water required in litres per minute (l/min)

P = population in thousands.

**(ii) National Board for Fire Underwriters (NBFU) formula** is given by

$$Q = 3860\sqrt{P}(1 - 0.01\sqrt{P})$$

Where Q = amount of water required in litres per minute (l/min)

P = population in thousands.

### Illustrative Example

A water supply scheme is to be designed for a Katankpe city in Abuja which has a population of 100,000 persons. Estimate the following:

- (i) Average daily demand
- (ii) Maximum daily demand if the maximum daily demand is 180% of average daily demand.
- (iii) Fire demand using the NBFU formula if the average water consumption is 250 *lpcd*.

### Solution

(i) Average daily demand = Population x per capita demand = 100,000 x 250 *lpcd* = 25 x 10<sup>6</sup> = 25 MI/d = 25,000 m<sup>3</sup>/d

(ii) Maximum daily demand if maximum daily demand = 1.8 x average daily demand.  
 = 1.8 x 25,000 m<sup>3</sup>/d  
 = **45,000 m<sup>3</sup>/d.**

(iii) Fire flow using NBFU formula:  $Q = 3860\sqrt{P}(1 - 0.01\sqrt{P})$

From the given parameters, Population = 100,000, hence P = 100. Therefore:

$$Q = 3860\sqrt{P}(1 - 0.01\sqrt{P})$$

$$Q \text{ (l/s)} = 3860\sqrt{100}(1 - 0.01\sqrt{100})$$

$$Q \text{ (l/s)} = 3860\sqrt{100}(1 - 0.01\sqrt{100})$$

$$Q \text{ (l/s)} = 3860 \times 10(0.9) = 3860 \times 9 = \mathbf{34,740 \text{ l/min}}$$

## 2.6: POPULATION FORECASTING



A water supply system is usually planned to serve the present and future needs of a community hence future population of the community must be assessed when designing its water supply system. This is based on foresight and good engineering judgment.

### **2.6.1: Population Forecasting Methods.**

Many methods are available for forecasting population but common ones include the following:

- (i) Graphical method
- (ii) Arithmetic method
- (iii) Geometric method
- (iv) Comparative method
- (v) Ratio and Component method
- (vi) Employment forecast or other utility connection forecast.

These methods are based on different assumptions and hence give different results. The selection of a method to be used for forecasting depends on the amount and type of data available and whether the projection is made for short or long term. However, in general terms population and its rate of growth depends on (i) Birth and death rates (ii) Migration and Immigration rates (iii) Annexation (iv) Urbanization and commercialization and (v) Industrialization.

In this section the graphical, arithmetic and geometric methods which are commonly used in Nigeria are discussed below.

### **2.6.2: Graphical Method**

In the graphical method of forecasting future population, the population in the past years are plotted against time. By use of his judgment, the forecaster extends the graph into the future such that it fits the trend of past population growth. The future population is thus predicted by means of graphical extrapolation.

### **2,6.3: Arithmetic Method**

In the arithmetic method of population forecasting, the rate of population change is assumed to be constant, that is;

$$\frac{dP}{dt} = K_a$$

$dP = K_a dt$ , where  $K_a$  is constant growth rate,  $P$  = population,  $t$  denotes time and  $\frac{dP}{dt}$  is the change of population with time.

Integrating within limits of  $P$  ( $P_i, P_f$ ) and  $t$  ( $t_i, t_f$ ) we have:

$$\int_{P_i}^{P_f} dP = K_a \int_{t_i}^{t_f} dt$$

$$P_f - P_i = K_a (t_f - t_i)$$

$$P_f = P_i + K_a (t_f - t_i).$$

The method is commonly used for short to medium term estimates of 1 to 10 years.

### Worked Example

The census records of Damaturu City are as given below. Estimate the population of the City in the year 1970 assuming arithmetic trend in growth.

Year	Population
1930	62,000
1940	74,000
1950	85,000
1960	100,000

### Solution

For the 1930 and 1940 census records:

$$K_a = \frac{74,000 - 62,000}{10} = \frac{12,000}{10} = 1200$$

For the 1940 and 1950 census records:

$$K_a = \frac{85,000 - 74,000}{10} = \frac{11,000}{10} = 1100$$

For the 1950 and 1960 census records:

$$K_a = \frac{100,000-85,000}{10} = \frac{15,000}{10} = 1500$$

$$\text{Average } K_a = \frac{1200+1100+1500}{3} = \frac{3800}{3} = 1266.66$$

$$P_f = P_i + K_a (t_f - t_i).$$

$$P_{1970} = P_{1960} + 1266.66 (1970 - 1960).$$

$$P_{1970} = 100,000 + 1266.66 \times 10 = 112,666.66 = \mathbf{112,670}.$$

#### 2.6.4: Geometric Method

The Geometric method of population projection is based on the assumption that population will increase in proportion to the present population. That is, the rate of population change is equivalent to the population at a given instant.

$\frac{dP}{dt} = K_g P$ , in which  $K_g$  = geometric constant, integrating between the initial population  $P_i$  at the year  $t_i$  and population  $P_f$  at the forecast year  $t_f$ . We have:

$$\int_{P_i}^{P_f} \frac{dP}{P} = k_g \int_{t_i}^{t_f} dt$$

$$[\ln P_f]_{P_i}^{P_f} = K_g (t_f - t_i)$$

$$\ln P_f - \ln P_i = K_g (t_f - t_i)$$

$$K_g = \frac{\ln P_f - \ln P_i}{(t_f - t_i)}$$

$$\ln P_f = \ln P_i + K_g (t_f - t_i) \text{ ---- (1)}$$

From equation (1) if population is plotted on logarithmic scale and time plotted in a linear scale, a straight line will be obtained and the slope of the graph gives  $K_g$ . Before the choice of whether to use either the arithmetic or geometric method to forecast population, the past population values are plotted on ordinary graph paper. If the relationship between population and time is approximately linear, then arithmetic method should be used in forecasting the population. If the graph is concave upwards the geometric method may be employed.

#### Illustrative Example

The census record of a Biu town in North East Nigeria is given below. Estimate the population of the town in 1970 given that population growth trend is geometric.

Year	1930	1940	1950	1960
Population (in 1000)	62	74	85	100

### Solution

For 1930 and 1940 census records

$$K_{g1} = \frac{\ln\left(\frac{74}{62}\right)}{10} = 0.01769$$

For 1940 and 1950 census records

$$K_{g2} = \frac{\ln\left(\frac{85}{74}\right)}{10} = 0.0138$$

For 1950 and 1960 census records

$$K_{g3} = \frac{\ln\left(\frac{100}{85}\right)}{10} = 0.0163$$

$$\text{Average } K_g = \overline{K_g} = \frac{K_{g1} + K_{g2} + K_{g3}}{3} = \frac{0.01769 + 0.0138 + 0.0163}{3} = 0.0159$$

$$\ln P_{1970} = \ln P_{1960} + \overline{K_g} (10)$$

$$\ln P_{1970} = \ln 100,000 + 0.0159 (10)$$

$$\ln P_{1970} = 5.069$$

$$P_{1970} = e^{5.069} = 117,200$$

### 2.6.5: Comparative Method

The future population can be predicted by plotting the population of several cities having similar pattern of growth. The population of the city under study is expected to grow in a

similar manner to other older and larger cities. The forecast is made by extrapolating the population curve of the city under study into the future according to the trend of the population curve of other cities.

#### **2.6.6: Ratio and Component method**

The growth of population of a smaller area is closely related to the growth of the population of the region in which the smaller area is situated. Thus the future population of the smaller area can be estimated by using the forecast of the future population of the region. Population department or commission usually forecast the future population of the region. Using the values, the future population of the area under study can be estimated. Thus

$$\frac{P_f}{P'_f} = \frac{P_i}{P'_i} = k \text{ (constant)}$$

$P_f$  = the population forecast for the area under study.

$P_i$  = the population of the area at the last census.

$P'_f$  = future population for the region.

$P'_i$  = population of the region at the last census.

#### **2.6.7: Employment Forecast or other utility connection forecast**

In this method, future population is estimated by using employment forecast. From the past data of population and employment, the ratio is plotted and population obtained from the projected employment forecast. This procedure is similar to that of ratio method. Similar procedure can be utilized from forecast of various utility service connections such as telephones, gas, water etc.

### **2.8: Design Period**

A water supply scheme may include huge and costly structures (for example dams, reservoirs, treatment works etc) which cannot be replaced or expanded in their capacities easily or conveniently. Therefore, to avoid future complications of expansions, the various components of a water supply scheme are deliberately made larger in order to satisfy the community needs for a reasonable number of years to come. The future period for which a provision is made in the design of the different components of a water supply scheme is known as the **design period**.

The design period should neither be too long or too short. The design period can also not exceed the useful life of the component structure.

### 2.8.1: Factors governing the selection of the design period.

The factors which guide the selection of design period for a water supply system are itemized as follows:

- (i) The useful life of the component structures and equipment used. The design period should not exceed stated values.
- (ii) Initial capital, operation and maintenance cost.
- (iii) The availability of capital.
- (iv) Ease and difficulties to be faced in system expansion if undertaken at a later date.
- (v) The availability of the expected supply at the end of the design period.
- (vi) The change in the purchasing power of money during the design period.

### 2.8.2: Typical design period values

In the design of water supply projects, design period is typically assumed to be between 20 to 30 years and this period does not include the period needed for project completion. The 20 to 30 year period may be varied with respect to certain components of the water scheme based on selection factors itemized previously. Typical design period recommended for different components of a water supply project are:

Item	Design period in years
<b>Storage by dams</b>	50
<b>Pumping</b>	
(i) Pump house	30
(ii) Electric motor and pumps	20
(iii) Water treatment plant	20- 50
(iv) Distribution system	20-50

## 2.9: Sources of Water and their Characteristics

After water demand has been estimated, the next necessary step is to look for source(s) that meets the quantity and quality requirements. This section an overview of the possible water supply sources that can be utilized for water supply systems is presented.

The source of water determines the system of collection, purification , transmission and distribution works to be used. When selecting the source of water supply to meet a community water demand , the following factors are considered (Al-Layla et al, 1978):

- (a) The quality of raw water
- (b) The volume of water available
- (c) Permanency and Reliability of source(s)
- (d) Elevation of the water level in relation to the proposed area to be served.
- (e) Availability of funds.

## **2.9: Sources of Water**

Common sources of water are rainwater, surface water and groundwater.

### **2.9.1: Rain Water**

Rain water is rarely used for municipal water supply because of the limitation imposed by non-availability of large surface areas (such as roofs) and paved ground surfaces where it can be collected. Rain water finds use in very small communities that do not have other sources of water supply ( deserts) or in areas where water is very hard and unpalatable. Rain water is generally collected from roofs of buildings and stored in cisterns for domestic consumption. It may also be collected in reservoirs ,but large areas where rain water could be collected strictly as rain water may not be available (rain water if allowed to flow over ground will loose its purity ). Rain water is soft and is most suitable for laundry purposes.

The advantages of rain water includes:

- (a) It is suitable for use in washing machines
- (b) It causes no calcification in washing machines
- (c) It is obtained free of charge and requires no elaborate purification system
- (d) It does not require transmission networks.

The absence of minerals in rainwater makes it insipid and when in equilibrium with atmospheric gases (carbon dioxide) it is corrosive. The level of pollutants in rainwater depends on the

environmental air quality. Thus in cities with large industrial presence where by poisonous gases and particulates are emitted into the atmosphere , rainwater can be very impure.

The components of rainwater system include roof, filters and storage.

## **Roof**

Rainwater is usually collected from the roof of buildings. It is preferred that the roof be pitched to increase the velocity of runoff thereby reducing the time the water is in contact with harmful substances. The roofing material should not secrete any harmful substances and should be resistant to weathering. Concrete , plastic or tiled roofs are satisfactory but roofs made of asbestos, bitumen and grass are not suitable. Water collected from thatched roofs are not suitable for drinking purposes without treatment because they absorb organic matter from the roof. In order to optimize the quantity of water collected from the roof , special gutters are designed; the eaves, size of gutter, outlet spacing and rain water pipes depend on the maximum volume of rainfall/ runoff estimated to be collected from the roof. The gutters are sloped 1in 3600 towards the outlets. PVC is a suitable material for the gutter.

## **Filters**

The preferred filter used is the self -cleaning filters which do not retain dirt and therefore do not permit germination to take place on the filter material unlike sand and gravel. The filter material is placed in an upright position.

## **Storage**

In rural communities, collected water may be stored in pots and cisterns for domestic consumption. However, the modern trend is to design reservoirs both underground and surface level storage tanks

### **2.9.2: Surface Water**

Rivers, lakes, ponds and impounded reservoirs are grouped as surface water. Surface water is exposed to contamination and hence it must be treated before use. It may contain both organic and inorganic impurities, gases, and microorganisms. It is generally used for drinking purposes when the groundwater supply is inadequate in quantity.

Rivers may be used to supply water to a community throughout the year and in situations where it is inadequate, it may be stored during times of rains or flood and then supplied to the community however river water must adequately treated before use due to pollution.



Deep lakes and ponds having sufficiently large areas can be utilized for municipal water supply. The water from these sources may be of better quality than the river quality and can often be used for domestic purposes without much treatment. Water can be drawn from deeper layers where the temperature is uniformly low and without dense plankton life.

### **2.9.3: Impounded Reservoirs.**

The excess amount of water received during rains and floods may be stored to be used during dry periods and to achieve this, an impounded reservoir is constructed by building a dam across a stream. Water quality from some impounded reservoirs may be sufficiently safe, attractive and palatable enough to be used without treatment except protective disinfection. Impounded reservoirs are generally multi-purpose where they are constructed to serve the needs of water supply, waste water disposal, irrigation, flood control, water power, inland transport, aquatic life, fishing and recreation. Impounded reservoirs may also developed for the single purpose of water supply only.

### **2.9.4: Groundwater .**

There are two sources of groundwater. Ground water is formed by rainfall which permeates into the ground through the pores or fissures in the rock formation and finally reaches the underground water table as well as the water from streams, lakes and reservoirs which permeates through the soil to reach the underground water table. When the level of the ground water is free to rise and fall, flow is unconfined or free and the groundwater table follows the slope of the ground surface. When the aquifer underlies an impervious stratum, flow is confined and it is similar to flow of water in a pipe under pressure. If the pressure head of the confined water is greater than the distance of water from the ground surface, artesian water will be available. Groundwater varies in purity depending on the geological conditions of the soil through which it flows. As water flows through a soil strata, it absorbs from the soil some of the soluble gases and salts. The degree of treatment for a ground water source depends on the type of water-bearing strata. Water found in alluvial sand may be polluted due to its proximity to the earth's surface, and it is therefore necessary to treat such waters before use. Therefore, detailed information regarding the geological condition of a locality is essential to determine the safety of a water supply from an underground source.

## **2.10: WATER QUALITY**

The quality of water depends upon the physical, chemical and biological characteristics. Natural water contains impurities but pure distilled water is composed of hydrogen and oxygen. To obtain desired water quality requires treatment. The required treatment depends on the quality of the raw water and the desired quality of the treated water.

### **2.10.1: Water-borne diseases.**

Water can be an environment suitable for the growth of microorganisms. If proper care is not taken, disease causing organisms (pathogens) may enter water and be carried to consumers resulting in the spread of diseases. Examples of water-borne diseases are cholera, typhoid, paratyphoid, amoebic dysentery and others.

## **2.11: Examination of Water**

Water to be used for domestic purposes is expected to be palatable and free from objectionable impurities. The quality of water is judged by the following three types of tests namely : (1) physical (2) chemical and (3) bacteriological

### **2.11.1: Physical tests**

Many of the constituents used to identify the physical characteristics of water are presented in the table --- below and discussed as follows.

(i) **Colour:** Water should be colourless . The presence of colour suggests that water contains dissolved and colloidal matter which is objectionable in drinking water supply.

(2) **Turbidity.** Water is a state of turbidity when it contains such substances as silt, clay, and finely divided organic matter . This is usually the case with surface water during rainy season. Groundwater is usually clear. Turbidity may be due to organic and inorganic impurities suspended in water. Turbidity interferes with the passage of light through the sample of water. The level of turbidity in a water sample is determined by means of turbidimeter.

(3) **Taste :** Potable water should not have bad taste. The presence of small amount of salt may impact taste in water and possibly make water unpalatable. Iron and manganese impacts bad taste in water.

(4) **Odour:** The slightest odour in water is objectionable. The intensity of odour can be expressed as a threshold odour number. The threshold odour number of a water sample is obtained by diluting a quantity of sample to 200 ml, in order for the odour to be barely perceptible when compared to odour free water.

(5) **Temperature:** Hot or very cold water is objectionable . Ideal temperature should be between 7 °C and 12 °C . Information relating water temperature is important because it affects such water properties as viscosity, density and surface tension as well as solubility of chemicals and bacteria activity . High temperatures are detrimental mainly because the increase corrosion rate.

### **2.11.2: Chemical tests**

Chemical composition of surface water depends on the characteristics of the catchment area. Groundwater acquires the characteristics of the soil through which it flows. The following tests are conducted to evaluate and control the quality of water.

(1) **pH value:** The pH value of water indicates whether water is acidic or alkaline. pH values higher than 7 indicate alkalinity and if less than 7, it shows acidity. The pH value of water is important in water as the control of coagulation process, removal of Iron and manganese and taste and corrosion control is impacted by the pH value of water.

(2) **Carbon dioxide :** Excess carbon dioxide in water is a disadvantage because it makes water corrosive to metals. It may be present in water in the form of carbonates, bicarbonates or as free CO<sub>2</sub>.

(3) **Hardness:** The presence of salts of calcium and magnesium make water hard. Under acidic conditions, water can dissolve many salts. To a certain degree hardness may be beneficial to health but when present to a high degree it affects taste of water and consumption of soap when washing. Hardness are of two types namely : Temporary or permanent. Temporary hardness attributable to the carbonate or bicarbonates of calcium and magnesium salts. Temporary hardness can be removed by boiling. Permanent hardness is due to sulphates, chlorides, nitrate and silicate of calcium and magnesium. A combination of these is called total hardness.

Hardness is expressed as mg CaCO<sub>3</sub> / l of water. The classification of water in relative terms of hardness is as presented in table below:

**Table 1: Classification of waters in Relative terms of Hardness.**

Degree of Hardness	Hardness of CaCO <sub>3</sub> (mg/l)
Soft	0- 55
Slightly hard	56 - 100
Moderately hard	101-200
Very hard	201-500

(4) **Chlorides:** Excess concentration of chloride in water impacts a bad taste. Chloride concentration should not exceed 250 mg/l. Chloride concentration higher than 250 mg/l does not create a health hazard but the water may not be palatable to persons not accustomed to the taste. Excessive amounts of chlorides is undesirable for a number of reasons which includes disagreeable taste and the corrosion it causes to pipes and plumbing fixtures. Prolonged ingestion of excessive amounts of chlorides is reported to affect health.

(5) **Iron :** Iron in water impacts bitter taste. It may be present in the form of carbonate or sulphate. Iron is found in groundwater because of the presence of hematite below ground surface, and iron is soluble in water containing carbonic acid. When water has enough oxygen or when it comes into contact with oxygen, dissolved iron may precipitate as flocs of ferric hydroxide. Organisms which utilize iron or its compounds also known as iron bacteria cause tastes and odour in water. Water which contains iron is not suitable for most industrial purposes. It is not suitable for use in laundries, paper mills and other manufacturing industries. When iron is more than 0.1 mg/l in water, its removal becomes necessary.

**(6) Manganese:** Manganese is often found in water along with iron. It gives unpleasant taste when its concentration exceeds 0.5mg/l . Impounded water often contain manganese but it usually mixed with sludge at the bottom. White clothes becomes yellowish if washed with water containing manganese. The concentration of manganese should be less than 0.1 mg/l.

**(7) Oxygen content:** Surface water is usually saturated with dissolved oxygen but when waste water is discharged into rivers the oxygen content is depleted . Groundwater drawn from great depths suffers deficiency in dissolved oxygen.

**(8) Hydrogen Sulphide:** The presence of hydrogen sulphide in water makes water unpalatable by producing bad taste, and odour . Hydrogen sulphide is found in ground water due to its contact with particular types of geological strata.

**2.11.3: Bacteriological tests:** The bacteriological quality of drinking water is determined by the presence of the coliform group of bacteria. Various pathogens are found in water and it is often difficult to detect their presence by direct analysis because they die quickly. Along with the pathogens, organisms of the coliform group are present in large numbers in human intestine. Thus the presence of coliform organisms in water indicates contamination. The presence of coliform organism suggests faecal pollution and indicates that the water is potentially dangerous. Coliform organisms are suitable indicators of contamination because they die in a short time and can be easily identified. *Escherichia coli* of the coliform group found in human and animal intestine are of great faecal significance. Bacteriological tests are conducted to determine the presence of coliform organisms in water. The quality of water is determined by the number of coliforms which can be counted in a particular volume of water. The presence of any type of coliform organism in treated drinking water suggests either inadequate treatment or access of undesirable substances to the water after treatment.

## 2.12: DRINKING WATER SUPPLY STANDARD

Drinking water should be safe and palatable, hence it is important to limit the concentration of impurities allowed in water supply. Every water must conform to certain standards prescribed by public health authorities. Standards are generally not absolute and may vary with local conditions and cost of treatment. The WHO Standards for drinking water as given in table 2 serves as guide.

**Table 2 : Desirable and Permissible Concentration of Chemical Substances and Properties affecting Potability.**

Substance or Characteristic	Undesirable effect that may be produced	Highest desirable level	Maximum permissible level
Total solids	Taste	500 mg/l	1500mg/l
Colour	Discolouration	5 units	50 units

Suspended matter	Turbidity	5 units	25units
Substances causing tastes	Tastes	Unobjectionable	Unobjectionable
Substances causing odours	Odours	Unobjectionable	Unobjectionable
Iron	Taste, discolouration , turbidity, deposits	0.1mg/l	1 mg/l
Manganese	Taste, discolouration , turbidity, deposits	0.05mg/l	0.5 mg/l
Copper	Taste, discolouration , Corrosion	0.05mg/l	1.5 mg/l
Zinc	Taste, opalescence, sand like deposits	5.0mg/l	15mg/l
Calcium	Excessive scale formation	75 mg/l	200mg/l
Magnesium	Hardness, taste, gastro intestinal irritation in the presence of sulphate	30 mg/l	150 mg/l
Sulphate	Gastro intestinal irritation in the presence of magnesium and sodium	200mg/l	400 mg/l
Chloride	Taste, corrosion, in hot water	200mg/l	600mg/l
pH	Taste, corrosion	7 to 8.5	6.5 to 9.2
Total hardness	Excessive scale formation	100mg/l	200 mg/l
Phenolic compounds (as phenol)	Tastes	0.001	0.002mg/l
Mineral Oil	Tastes and odour after chlorination.	0.01mg/l	0.30mg/l

**Source :** Based on International Standards for Drinking water, WHO (1971)

### 2.13: Water Quality and Testing

Water from ground or surface sources may not always be potable for drinking and may thus need some level of water treatment before delivery to the water supply system. The water quality issues often encountered in different water sources are presented below.

<b>Water Source</b>		<b>Type of quality issues</b>
<b>Surface Water</b>	(i) Lakes and ponds	Development of algae on top, development of Micro-organisms, high turbidity in bottom layers. May be affected by organic and chemical pollutants by disposal of wastewater.
	(ii) Rivers, irrigation canals	Organic debris, mineral salts May be affected by organic and chemical pollutants by disposal of wastewater. Ground Water
<b>Ground Water</b>	Well, tube wells, hand pump etc	Salinity, fluoride, alkalinity, hardness Chemical contaminations due to disposal of domestic waste/industrial chemical near by

Physical, Chemical and Bacteriological tests are necessary to be conducted

- (a). Physical tests include temperature, turbidity, colour, taste, and odour.
- (b) Chemical tests including pH, alkalinity, acidity, hardness, calcium, magnesium, iron, manganese, copper, zinc, aluminium, sulphates, fluorides, chlorides, nitrates, total dissolved and suspended solids, tests for toxic chemicals (lead, mercury etc.), test for radio-activity.
- (c.) Bacteriological examination for presence of bacteria like coliform, E-coli

### **2.13.1: Sampling Frequency**

Water from all the sources like wells/tube well/hand pump or collection point like stand post or Household level/intermediate storage tank should be tested at regular intervals. Normally, one sample for every 5000 population should be tested in each month. Additional tests should be conducted during rainy season and during epidemics as the need arises. Where there are issues of biological contaminations, samples should be taken every week from the specified water source.

### **2.13.2: Sampling Methods**

#### **a. Sampling for physical and chemical test**

- Samples should be collected in inert materials like glass or polythene.

- Sample bottle must be cleaned prior to taking samples as directed by laboratories.
  - About 2.5 litres is required for testing from each sample.
  - Prior to filling, the sample bottle must be rinsed 2-3 times with water to be collected.
  - Sample should reach the testing place within 72 hours of collection.
  - Certain parameters like pH, temperature chlorine etc may change during transport and it is advisable if they are tested on spot by specific kits.
  - Samples collected from wells should be taken only after the well has been pumped for sufficient times so that the sample will represent ground water.
- b. Sampling for bacteriological test**
- Sterilised bottle, as directed by laboratory should be used for sample collection.
  - While collecting sample, hand should not touch the bottle neck or stopper. Bottle should be held from the base, filled without rinsing and stopper be closed immediately. Bottle should have some air space left and should not be filled completely. Finally, brown paper should be wrapped for avoiding further contamination of water.
  - Size of sample should be at least 250 ml (1/4th of litre).
  - The sample should preferably be analysed within one hour after collection. The test of the sample should be done maximum within 24 hours.
- Note for collecting sample from various sources
- While taking sample from river, lake, etc. sample should be taken from middle of bank. Stagnant water should be avoided for sample.
  - While taking sample from tap (HH or stand post), water should be allowed to flow for two to three minutes prior to taking sample. Tap from which sample is collected should be clean and free from grease etc. • While taking sample from hand pump, water should be allowed to flow for four to five minutes prior to collection of sample.
  - While collecting sample from well/bore well, sample be collected from discharge end through fitted mechanical pump.

## **2.14: WATER TREATMENT SYSTEMS**

### **Introduction**

The objective of municipal water treatment is to provide a potable supply – one that is chemically and microbiologically safe for human consumption. For domestic uses treated water must be aesthetically acceptable that is, free from apparent turbidity, colour, odour and objectionable taste. For industrial uses, quality requirements are usually more stringent than for domestic supplies. The purpose of water treatment systems is to bring raw water up to drinking water quality. The particular type of treatment equipment required to meet these standards depends on the source of water. Most large cities rely mainly on surface water sources while most small towns or communities are more dependent on ground water for their water supply. Surface water tends to have more turbidity and more susceptible to microbial contamination

hence it usually necessary for such water to undergo filtration process. On the other hand, groundwater is often uncontaminated and has relatively little suspended solids hence filtration is usually less important. Groundwater however may have objectionable dissolved gases that will have to be removed and hardness (ions of calcium and magnesium) removal may also be needed.

Normally, water supplied for drinking is treated at head works under the water supply system. However, water needs treatment even at household level as there may be chances of water contamination while transmission of water. Type of treatment depends on quality of raw water and source. The following table lists some of the common methods of water treatment used in water supply system:

Type of Filtration	Purpose	Type of unit
Sedimentation	Removal of suspended solids like sand, clay, silt etc.	Sedimentation tanks Sedimentation with tanks
Sedimentation with coagulation	Removal of suspended solids, colour, odour, taste, turbidity etc.	Sedimentation with chemical input
Filtration	Removal of micro organism and colloidal matter	Slow/rapid sand filter Water
Water softening plant	Removal of water hardness/salts	RO (reverse osmosis plant)
Disinfection	Removal of pathogenic bacteria	Chlorination
Specialised water treatment plants	Removal of fluoride	De-fluoridation units,
	Excessive salinity	De-salination plants

## 2.15: WATER DISTRIBUTION SYSTEM

After the water has been properly treated and made safe and wholesome, it has to be supplied to the consumers in their individual homes. The water has therefore, to be taken from the treatment plant to the roads and streets in the city and finally to the individual houses. The function of carrying the water from the treatment plant to the individual homes is accomplished through a well-planned distribution system. Distribution system is used to describe collectively the facilities used to supply water from its source to the point of usage. Its purpose is to deliver water to consumer with appropriate quality, quantity and pressure. A distribution system consists of *pipe lines* of various sizes for carrying water to the streets, *valves* for controlling the flow in the pipes, *hydrants* for providing connections with the water mains for releasing water during fires; *meters* for measuring discharges; *service*



*connections* to individual homes; *pumps* for lifting and forcing the water into the distribution pipes, *distribution or service reservoirs* for storing the treated water to be fed into the distribution pipes. The water may be supplied to the public continuously for all 24 hours of the day or it may be supplied intermittently during certain fixed hours of the day. Water may also be pumped either directly into the distribution pipes or it may first be stored in a distribution reservoir and then fed into the distribution pipes.

### **2.15.1: Requirements of a Good Water Distribution System**

To ensure proper functioning, a good distribution system must meet the following requirements.

- (i) It should be capable of supplying water at all intended places within the city with adequate or sufficient pressure head.
- (ii) It should have capacity to provide water to meet firefighting or fire suppression requirements while also meeting other demands.
- (iii) It should be cheap with least capital construction cost. This is an important consideration as the cost of the distribution system can be as high as 70 to 80 % of the total cost of a water supply scheme hence it has to be properly planned, designed and constructed at optimum cost.
- (iv) It should be simple and easy to operate and repair thereby keeping the cost of repair, maintenance and operation to the minimum.
- (v) It should be safe against any future pollution of water. This may be achieved by keeping the water pipe lines above and away from sewerage and drainage lines by sufficient amounts and by ensuring good sanitary conditions in areas through which distribution pipes have to pass.
- (vi) It should be safe against pipe failure by bursting.
- (vii) It should be reasonably watertight in order to minimize leakage losses.

### **2.15.2: Layouts of Distribution Networks**

Distribution pipes are usually laid below road pavements and as such their layouts generally follow the layouts of the roads. Generally, there are four different types of pipe networks; any one of which, either singly or in combinations, can be used at a particular place depending upon the local conditions and orientation of roads. These systems are:

- (1) Dead end system
- (2) Grid iron system

- (3) Ring system and
- (4) Radial system

### (1) Dead-end system

In the *dead-end system* is also called *tree or branched system*, there is one main supply pipe from which originates (generally at right angles) a number of sub main pipes. Each sub main then divides into several branch pipes called laterals. From the laterals, service connections are made to the consumers. A typical plan of such network is as given in Figure 2.2. This type of layout is adopted in old towns and cities which have developed haphazardly without properly planned roads. The water supply is taken along the main roads and branches taken where needed, thereby resulting in numerous dead ends.

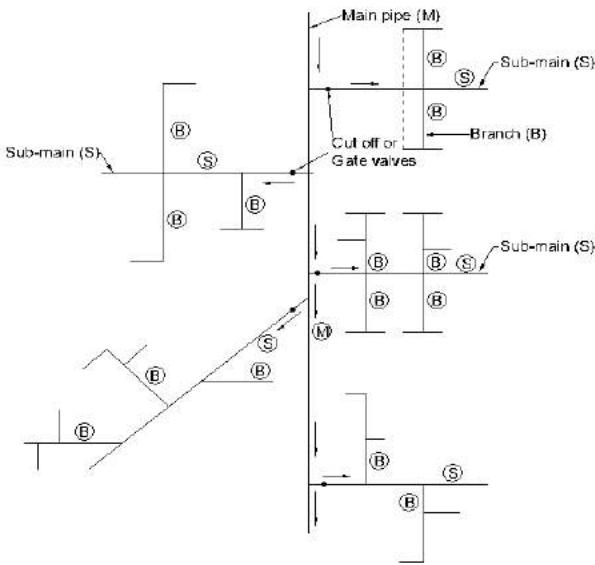

**Figure 2.2:** Diagram of Dead end system

### **Advantages of the Dead end system.**

The advantages associated with the dead end system are as follows:

- (a) The distribution system can be easily solved and thus it is possible to easily and accurately calculate the discharges and pressures at different locations in the system.
- (b) Fewer number of shut-off or sluice valves are required in the system.
- (c) Shorter pipe lengths are used and the laying of pipes is easier.
- (d) It is cheap and simple and the system can be expanded or extended easily.

### **Disadvantages of the dead end system**

The disadvantages associated with the dead end system of water distribution layout are as follows:

- (a) As water can only reach a particular point through one direction in this method, any damage or repair in any pipeline will lead to complete stoppage of water supply in the area being fed by that pipe. Hence any damage or repair in a main pipe results in shortage of water to the service area causing considerable inconvenience to the consumers.
- (b) There are numerous dead ends in this system leading to stagnation of water thereby impeding free circulation of water. The stagnation may lead to degradation in water quality. Stale water must be removed periodically at the dead ends by means of scour or drain valves at the dead ends. This results in wastage of treated water and the need to give additional attention to the valves.
- (c) This system is not efficient for fire suppression. As discharges reaches a point from only one direction in this system, the supplies during fire fighting cannot be increased by diverting water from other directions thus this system can only provide limited supplies during fire fighting.

### **(2) Grid-Iron system**

In this system also known as reticulation system, the mains, sub mains and branches are all interconnected with each other as shown in Figure 2.3:. In well planned cities, the roads are usually developed in a grid-iron pattern, and the pipe lines in such places can easily follow them. Thus this system is suitably used in well planned towns and cities.

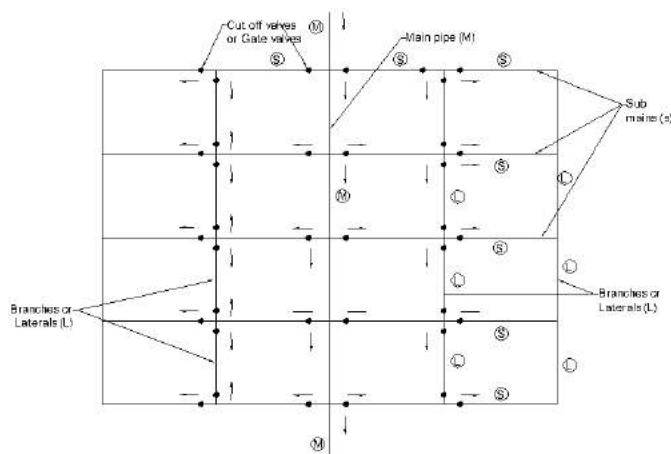

**Figure 2.3:** Grid-iron system

### **Advantages of the Gridiron system**

- (i) As the water reaches different points from more than one direction, the discharge to be carried by each pipe, the friction loss and the size of each pipe is reduced.
- (ii) During maintenance or repair of pipelines, only a small area is cut off from water supply as the valves are manipulated to divert water to places of need from other directions.
- (iii) Dead ends are eliminated in this system because of the interconnections and thus water remains in continuous circulation thereby preventing stagnation and staleness of water.
- (iv) This system is effective in fire suppression. During fire, more water can be diverted towards the affected point from other directions through closure and manipulation of different sluice valves.

### **Disadvantages of the Grid-iron system.**

- (i) Greater lengths of pipelines and larger number of sluice valves are required.
- (ii) Its construction cost is high
- (iii) The design is difficult and costlier. Calculation for the accurate determination of the sizes of the pipes and the pressure at various key points is tedious and requires expert designers and the use of computers.

### **(3) Ring or Circular system**

In this system, a closed ring, either circular or rectangular of the main pipes, is formed around the area to be served as shown in Figure 2.4. The distribution area is divided into rectangular or circular blocks, and the main water are laid on the periphery of these blocks.

The sub mains may be placed as shown in the figure. The ring system is very suitable for towns and cities having well planned roads. Sometimes, this system is used as looped feeder placed centrally around a high demand area along with the grid iron system and will improve the pressures at various points. The advantages and disadvantages of this system are the same as that of the grid iron system

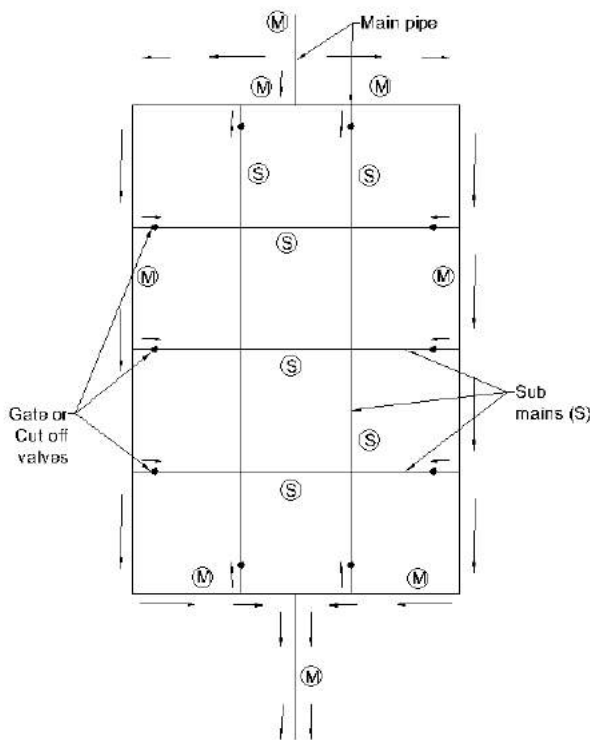
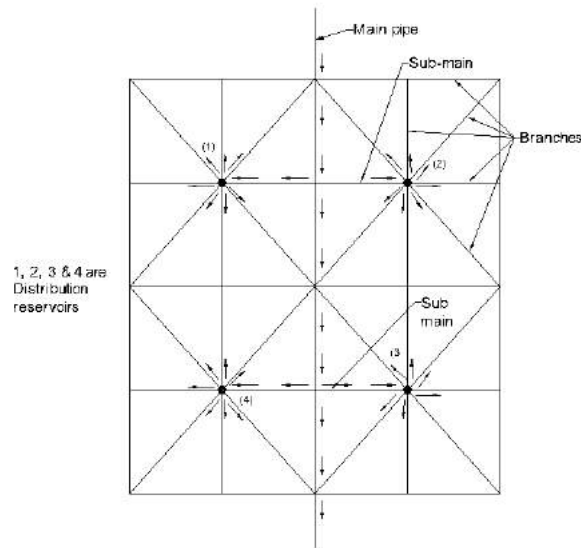

**Figure 2.4:** Ring or Circular system

#### **(4) Radial system**

If a city or town is having a system of radial roads emerging from different centres, the pipe lines can be best laid in a radial method by placing the distribution reservoirs at these centres. In this system, water is taken from the water mains and pumped into the distribution reservoirs placed at different centres as shown in Figure 2.5 The water is then supplied through radially laid

distribution pipes. This method ensures high pressures and efficient water distribution. The calculations for design sizes are also simple



**Figure 2.5: Radial system**

## **2.16: Methods of Distribution**

The main object of a distribution system is to develop adequate water pressures at various points of the consumer taps. Depending upon the level of the source of water and that of the city, topography of the area, and other local conditions and considerations, the water may be forced into the distribution system in the following three ways:

- (1) By gravitational system
- (2) By pumping system
- (3) By combined gravity and pumping system.

### **(1) Gravitational system**

In this system, the water from a source at high elevation is distributed to the consumers at lower levels by the action of gravity without the use of pumps. For this system to function effectively, the difference of head available between the source (or distribution reservoir at the treatment plant) and the community must be adequate to maintain adequate pressure at the consumer taps, after considering frictional and other losses in the pipes. This method is an economical and reliable method involving no pumping at any stage.

### **(2) Pumping system.**

In the pumping system, the treated water is directly pumped into the distribution pipes without storing it anywhere. The system is also referred to as *pumping without storage system*. High lift pumps which operate at variable speed to meet the variable demand for water are used in this system. In this regard, continuous attendance is needed at the pumping station to ensure that the required flow in the distribution system is achieved. If there is power outage, the system comes to a halt leading to stoppage of water supply. This method is not efficient as a fire suppression system as it is not able to respond to fire fighting needs if there is any fire outbreak during a power outage.

### **(3) Combined gravity and pumping system.**

In this system, treated water is pumped at constant rate and stored into an elevated distribution reservoir, from where it is distributed to the consumers by action of gravity. Sometimes, the entire water is first of all pumped into the distribution reservoir and many a times, it is pumped into the distribution mains and reservoirs, simultaneously. This method therefore combines both pumping and gravity flow and is sometimes called *pumping with storage system*.

The excess water during period of low demand is stored in the reservoir and supplied during high demand times. The pumps are operated at a constant rate which is adjusted in such a way that excess quantity of water stored in the reservoir during low consumption nearly equals the extra demand during high consumption. This system helps in operating the pumps at constant speeds at their rated capacities, thus increasing their efficiency and reducing their wear and tear. This method is quite reliable because certain amount of water can be supplied from storage or service reservoir even in the event of power outage or pump failure.

## **2.17: DISTRIBUTION OR SERVICE RESERVOIRS**

Distribution or service reservoirs are storage reservoirs which store treated water at suitable elevations so that supply can be properly maintained when demand exceeds the inflow from the trunk main. Service reservoirs help in the supply of water during emergencies (such as during fires, break downs, repairs etc) as well as in absorbing the hourly fluctuations in the normal water demand.

### **Functions of Distribution reservoirs.**

Functions performed by service or distribution reservoirs in a water distribution system are as follows:

- (i) They absorb the hourly variations in demand enabling the water treatment units and pumps to operate at a constant rate. Thereby reducing the repair, maintenance and operations costs and improve system efficiency.

- (ii) They help to maintain constant pressure in the distribution system. When not provided, pressure will fall as demand of water increases and if pumps do not respond immediately to it.
- (iii) The pumping of water can be done in shifts without affecting supply. A day's demand can be pumped in 8 to 16 hours.
- (iv) The water stored in the reservoir can be supplied during emergencies such as break down of pumps, during fire emergencies etc.
- (v) They help achieve overall economy due to the reduction in the sizes of pumps, pipe lines and treatment units.

From experience service reservoirs are sized to provide capacity to supply 10 to 12 hours in the minimum but this may be as high as 24 hours storage capacity to provide enough reserve capacity in the event of damage to pipeline or treatment works.

For small communities, storage capacity of reservoir should be adequate for demands for a period of 2 hours and 10 to 12 hours for large communities.

### **Types of Distribution Reservoirs**

Distribution or service reservoirs may be made of steel, reinforced concrete or masonry. Based on their elevation with respect to the ground, they may be classified as:

- (i) Surface reservoirs ; and
- (ii) Elevated reservoirs.

### **Surface Reservoirs**

Surface reservoirs are circular or rectangular tanks constructed at ground level or below the ground level. They are thus called *ground reservoirs*. They are often constructed at high points in the city and if more than one high point exists in a city more than one reservoir may be provided and in which case the city is divided into several zones with a different reservoir provided for the different zones for water distribution. In the gravity type distribution system, water is stored in the ground service reservoir and then directly sent into the distribution system from there. However, in the combined gravity and pumping system of distribution, the treated water is first stored in a ground reservoir and then pumped into an elevated service reservoir from where it is supplied into the distribution mains.

### **Elevated Reservoirs**

Elevated reservoirs are rectangular, circular or elliptical overhead tanks erected at a suitable elevation above the ground level and supported on towers. They are constructed where the pressure requirements necessitates considerable elevation above the ground surface. They are constructed where the combined gravity and pumping system for water is adopted. Water is pumped into the elevated tanks from surface reservoirs and then supplied to the consumers.



## **2.18: APPURTENANCES IN THE DISTRIBUTION SYSTEMS**

In order to isolate and drain the pipeline sections for tests, inspections, cleaning and repairs; a number of appurtenances are provided at different suitable locations along the pipelines. They are described below:

### **(i) Gate valves or Sluice valves.**

A valve is a device which used for controlling the flow of water in the pipeline. With the help of valves, any section of a pipe line may be isolated for the repair of leak or breakage. Valves are fitted on all mains and sub mains. Gate or sluice valves are used to regulate the flow of water through the pipes. They are used in every main and sub main to isolate a portion of the system during repairs. Generally, they are used at intervals of not more than 160 – 250 m. Manholes or chambers are constructed at each valve location to provide easy access. In large pipelines which bring water from the source to the city, they are generally located along the pipeline at intervals of 3 to 5 kilometres in order to divide the pipeline into different sections to facilitate the cutting off different sections for repairs as the need arises.

### **(ii) Air valves**

An air valve is used at summits in the pipelines on both sides of the sluice valves for the removal of air. If an air valve is not provided, the presence of air will reduce the effective area of the pipe

### **(iii) Blow off valves or Drain valves or Scour valves or Wash out valves**

They are ordinary sluice valves which are located either at the dead ends or the lowest points in the mains. They are provided to blow off or remove sand and silt that may get deposited in the pipe line. They may also be used to remove water from the pipes by completely emptying the pipe to enable inspection or repairs etc

### **(iv) Check valve**

A check valve also known as Non- return valve is a valve that allows flow in one direction only. Water flowing in the opposite direction is automatically stopped by this valve. They may be installed on the delivery side of the pumping set so as to prevent the back flow of stored or pumped water, when the pump is stopped. Check valves are also installed on pump discharges to reduce water hammer forces on the pump.

### **(v) Hydrants**

Hydrants are used on the mains to provide a connection for fire-hoses to fight fire. It is a fitting on the pipeline and is provided mainly for the purpose of forming a connection for fire hose. There are two types of hydrants namely flush hydrant and post hydrant. The flush hydrant is placed inside a cast iron box which is level with the street surface. The post hydrant projects about one metre above the street surface. Hydrants should be placed at easily accessible locations. A good hydrant should meet the following requirements.

- (a) It should be such as to connect the hose or the motor pump easily to it.
- (b) It should be cheap.
- (c) It should be easily detectable when required during fire emergency
- (d) It should be functional during operation
- (e) It should allow undisturbed water flow when fully opened.

#### **(vi) Water meters**

Water meters are devices used for measuring the quantity of water flowing under pressure through the pressure conduit. It is necessary to measure the quantity of water supplied to domestic, commercial or industrial consumers in order to charge the consumers according to the quantity of water supplied to them.

A good water meter is expected to meet the following requirements:

- (a) It must record the entire water passing through it and must be capable of recording even slight discharges.
- (b) Its maintenance and repair should be easy
- (c) It should measure discharges within the maximum limit of 20% error.
- (d) It should have capacity to function efficiently at all pressures encountered in the mains.
- (e) It should cause minimum hindrance to the flow and cause minimum head loss when in operation.
- (f) It should prevent the back flow passing through it and should not be liable to clogging

### **2.19: PUMPS AND PUMPING**

A pump is a mechanical device that adds energy to water or other liquids. In many water supply schemes pumping may be required to lift water from a river, lake or reservoir to the treatment plant. After treatment, water may need to be lifted to either supply water directly into the mains or to overhead storage tanks from where it is distributed by gravity. It may also be necessary to employ pumps to increase pressure in the supply line. If wells are the source of supply, pumps are required to lift the water from the wells. In most water distribution systems, pumps are needed to raise the water in elevation and to move it through

the network of water mains under pressure. One way of classifying pumps is by their application in the system. Pumps that lift the water from the river or lake and move it to a nearby treatment plant are called *low-lift pumps*. They move large quantities of water but relatively low discharge pressures. The pumps which discharge the treated drinking water into the transmission and distribution system are called *high lift pumps*; they operate under relatively high heads or pressures. When it is necessary to increase the pressure within the distribution system or to raise the water into an elevated storage tank, *booster pumps* can be used for such purposes. In summary, pumping may be required in a water supply system for the following purposes:

- (i) For lifting raw water from the source of supply like reservoir, lake or well
- (ii) For lifting treated water to elevated tanks or reservoirs
- (iii) For delivery of treated water to consumer taps at reasonable pressure head.
- (iv) For boosting line pressure.
- (v) For supplying water under pressure to fire hydrants
- (vi) For miscellaneous operations at the water treatment plants such as (a) for backwashing of filters (b) for pumping chemicals and (c) for dewatering of tanks, basins, sumps etc.

Pumps may also be classified according to the mechanical principles on which they operate. The two basic types are *positive displacement pumps* and *centrifugal pumps*. A positive displacement pump delivers a fixed quantity of water with each revolution of the pump rotor or piston. Centrifugal pumps are the most common type used in water supply systems. The capacity of the pump is a function of the pressure against which it operates in the system. a centrifugal pump adds energy to water by accelerating it through the action of a rapidly rotating impeller. Centrifugal pumps have several advantages over positive displacement pumps. They are simple, with only one moving part – the impeller, no internal valves are required and there is no need for internal lubrication. Also they operate very quietly. They have the following disadvantages: - effect of pressure on pump output and efficiency, the need to prime the pump before it is operated. Pumping involves filling the pump casing and suction line with water.

### **Characteristics of Centrifugal Pump**

The maximum head developed by the pump when the discharge valve is closed is called *shutoff valve*. The *shutoff head* exists only for a short duration as the head decreases as the discharge valve is gradually opened. The efficiency of the pump increases as the discharge Q increases until it reaches its maximum value and then decreases. Pumps are defined by the parameter known as specific speed. Specific speed is defined as the speed at which a pump discharges a unit flow under a unit head at maximum efficiency. It is given by:

$$N_s = \frac{N\sqrt{Q}}{H^{3/4}}$$

Q = discharge in litres per second

H = Head in metres, N = rotation speed in rpm

### SYSTEM HEAD CURVE

To effectively design of a pumping station, it is necessary to know the *total dynamic head* (TDH) against which the pump is to operate. The TDH is represented by the equation:

$$TDH = H_{ST} + h_{ls} + h_{ld} \text{ --- (1)}$$

Where  $H_{ST}$  = total static head (or lift); the difference in elevation between the pumping source and point of delivery.

$h_{ls}$  = head loss in suction pipe

$h_{ld}$  = head loss in delivery pipe (friction, minor losses and velocity head, etc)

TDH = total dynamic H is the rise in total head across the pump.

Equation 1 may also be represented as:

$$TDH = H_{ST} + h_L + h_V \text{ ---- (1a)}$$

$h_L$  = total head loss in (including minor losses) through the suction and delivery pipes.

$h_V$  = velocity head ( $\frac{v^2}{2g}$ ) at the discharge end.

### Plot of system head curve

The plot of total dynamic head (TDH) against discharge is known as *system head curve*. Each point on the system head curve shows head consisting of: (i) static head  $H_{ST}$  (ii) head loss,  $h_L$  (iii) velocity head,  $h_V$ . The system head curve varies with discharge (Q) as  $h_L$  and  $h_V$  are both function of Q. The static water level may also change with fluctuating water levels. The total head loss consists of the sum of friction and minor losses namely: (1) head losses in the entire length of the pipe from the foot valve to the final point of delivery piping (friction) (2) loss in the valves (foot valve, non-return valve, isolation valves etc and (3) losses bends, tees, elbows, reducers etc. The system head curve changes when changes are made in the system, for instance: change in the length or size of pipe etc.

### Operating point or operating range of a pump.

The operating point of a pump is the point of intersection of the system head curve with the H-Q characteristic curve of the pump as shown. If the system head curve changes, the operating point will shift. In the case where the water level in the sump fluctuates, there will be two system head curves corresponding to low water level (LWL) and high water level (HWL). The range between

the operating points at low water level and at high water level is known as the *operating range* of the pump and this is due to fluctuation in water level in the sump.

### **Plot of operating point of pump**

#### **Selection of pumping units.**

Usually, the system head curve is given or known and it is therefore required to find a pump or pumps which will deliver the needed flow. In order to do this, the system head curve and the pump characteristic (H-Q curve) are plotted on the same paper and the operating point determined. The operating point (P) gives the head and flow at which the pump will be operating. Thus a pump is selected such that the operating point is as close as possible to the peak efficiency.

#### **Power Requirements of Pumps.**

The total dynamic head (TDH) against which a pump is to operate has previously been given and parameters defined in equation (1a) as:

$$TDH = H_{ST} + h_L + h_V$$

The velocity head ( $h_V$ ) at the discharge end is usually small and may be neglected in the computations of power requirements of pumps.

The total head loss ( $H_L$ ) consists of friction head loss in the pipe system computed using various formulae and energy loss encountered due to flow through fittings like bends, elbows, tees, valves etc. The energy loss through the fittings ( $H_{LF}$ ) may be computed by use of the following relationship:

$$H_{LF} = K \frac{v^2}{2g}, \text{ K is the respective fitting coefficient available in standard tables.}$$

Recall that the head loss due to pipe friction has previously been given by the expression:

$$h_f = \frac{f l Q^2}{12.1 d^5}$$

Where  $l$  = length of the pipe section (m),  $d$  = diameter of the pipe (m),  $f$  = coefficient of friction depending on material of make of the pipe.

If  $W$  kg is the weight of water lifted in one second through a height of  $H$  metres, the work done by the pump is equal to  $W \times H$  m-kg/s =  $Q \times w \times H$  m-kg/sec.

$$\text{Hence Water horse power (WHP) in metric units} = \frac{QwH}{75 \eta_p}$$

Where  $\eta_p$  = pump efficiency

1 metric Horse Power = 75 kg –m/sec

$$\text{Brake horse power (BHP)} = \frac{Q w H}{75\eta_p}$$

Where  $\eta_p$  = pump efficiency. If the pump is driven by electric motors, the electric horse power (EHP) is given by:

$$\text{E.H.P} = \frac{\text{BHP}}{\text{motor efficiency}} = \frac{\text{BHP}}{\eta_p} = \frac{Q w H}{75\eta_p\eta_m} = \frac{Q w H}{75\eta}$$

$\eta_m$  = efficiency of motor,  $\eta$  = overall efficiency, 1 metric HP = 736 watts = 0.736 kilowatt,  $w = 1000\text{kg/m}^3$

$$\text{Power in kilowatts} = \frac{9.81 Q H}{\eta}$$

### **Economical Diameter of Pumping mains**

The required HP of pump depends upon the total dynamic head which depends on friction head loss and velocity head both of which are dependent on the velocity of flow through the pumping mains. For a given discharge, reduction in the diameter of pipeline in order to reduce pipe cost results in increased pipe velocity which leads to increased friction loss that result in increased pumping cost. For optimum conditions, a diameter of pipe must be chosen such that the total annual pipe and pumping cost is a minimum. The diameter at which this is achieved is termed economical diameter of the pumping main. The economical diameter of a pumping main may be estimated by the empirical formula proposed by Lea as:

$$D = a\sqrt{Q}$$

Where D = diameter of pipe (m), Q = discharge through the pumping main ( $\text{m}^3/\text{s}$ ),

$$a = 0.97 - 1.22$$

### **Worked Example 1:**

Water is required to be pumped from the clear water tank of a treatment plant which is 2.5 metres deep with a maximum water level at 32.00 metres to an overhead tank at 80.00 metres at a discharge rate of  $0.225\text{m}^3/\text{s}$ . The distance is 1200 metres. Determine the economical or optimum diameter of the pumping main and the water horse power of the pump. Neglect minor losses and assume  $f = 0.04$  and  $\eta_p = 0.85$

### **Solution:**

$$\text{Discharge ( } Q \text{ )} = 0.225 \text{ m}^3/\text{s}$$

For determination of optimum or economical diameter of pumping main, we utilize the Lea empirical formula:

$$D = a\sqrt{Q}, \text{ assuming } a = 1.0, D = a\sqrt{Q} = 1.0\sqrt{0.225} = 0.474\text{m, use } 0.5 \text{ m}$$

If it assumed that the pump is fixed at maximum water level (32.00m) of the sump,

Maximum suction head = 2.5m

Delivery head = 80 – 32 = 48 m

Maximum static head,  $H_{ST} = 2.5 + 48 = 50.5$  m. The head loss in a pipe section is computed by the relation:

$$H_f = \frac{fLQ^2}{12.1d^5} = \frac{0.04 \times 1200 \times 0.225^2}{12.1 \times 0.5^5} = \frac{0.04 \times 1200 \times 0.225^2}{12.1 \times 0.03125} = \frac{0.04 \times 1200 \times 0.225^2}{0.378125} = \frac{2.43}{0.378125} = 6.426 \text{ m}$$

If other losses are neglected, the total head (H) is given by,  $H_{ST} + H_f$

$$H = H_{ST} + H_f = 50.5 + 6.426 = 56.93\text{m}$$

$$\text{Water Horsepower} = \frac{QWH}{75 \eta_p} = \frac{0.225 \times 1000 \times 56.93}{75 \times 0.85} = 200.93.$$

### Worked Example 2:

Wilberforce Island in Bayelsa State Nigeria has a population of 150,000 persons with average water demand of 160 litres per person per day. The static lift of the pump is 40 metres. Compute the BHP of the motor. The pumping main is 300m long and a diameter of 500mm. motor efficiency is 85%, pump efficiency is 75% and maximum daily demand is 1.5 times the average demand.

### Solution

$$\text{Average daily demand} = 150,000 \times 160 = 24 \times 10^6 \text{ litres / day} = 24,000\text{m}^3/\text{day}$$

$$\text{Average daily demand} = 24,000\text{m}^3/\text{day} = \frac{24,000}{24 \times 60 \times 60} = 0.278 \text{ m}^3/\text{sec}.$$

$$\text{Peak hour demand} = 1.5 \times 0.278 = 0.417 \text{ m}^3/\text{sec}.$$

Static lift,  $H_{ST} = 40\text{m}$

$$H_f = \frac{fLQ^2}{12.1d^5} = \frac{0.04 \times 300 \times 0.417^2}{12.1(0.5)^5} = 5.56 \text{ m}$$

$$\text{Velocity} = \frac{4Q}{\pi d^2} = \frac{4Q}{\pi \times 0.5^2} = \frac{4 \times 0.417}{\pi \times 0.5^2} = 2.12 \text{ m/s}$$

$$H_v = \frac{v^2}{2g} = \frac{(2.12)^2}{2 \times 9.81} = 0.23 \text{ m}$$

$$H = H_{ST} + H_L + H_v = 40 + 5.56 + 0.23 = 45.79 \text{ m}$$

$$\text{Over efficiency } \eta = 0.85 \times 0.75 = 0.64$$

$$\text{BHP of motor} = \frac{QwH}{75\eta} = \frac{0.417 \times 1000 \times 45.79}{75 \times 0.64} = 398$$

## 2.20: PIPE NETWORK ANALYSIS

Pipe network analysis involves the detailed and careful scrutiny of the fluid flow through a hydraulic network containing several interconnected branches and loops. In the design of a distribution system, a pipe network analysis must be done to determine the flow rates and pressure drops in the individual sections of the network, thus giving basis for selecting pipe diameters. The basic principles governing network hydraulics are:

- Conservation of mass – the fluid mass entering any pipe system will be equal to the mass leaving the system. In network analysis, outflows are lumped in nodes. A related principle is that at each junction (node), the algebraic sum of the quantities of water entering and leaving the node is zero.
- Conservation of energy – In any closed path or circuit in a hydraulic network, the algebraic sum of the energy (head losses) in the individual pipes is zero. Another way of stating it is that the difference in energy (head loss) between two nodes in a system must be the same regardless of the path that is taken (Bernoulli principle). One important tool that a network designer may use is the equivalent pipe method. It is the substitution of a complex system of pipes by a single pipe that will give an equivalent head loss at a given flow.

**1. Network Analysis by Conventional Method (Hardy Cross) :** The most common conventional method (not using computers) that is used in designing hydraulic networks is the Hardy Cross algorithm method. It involves iterative trial and error. One approach of Hardy Cross is the method of balancing the heads on the nodes by adjusting assumed flows in the pipe elements. Clockwise flows and corresponding head losses are assigned negative signs, and vice versa for positive signs. In the initial trial, initial values of flows in all pipe elements are assumed subject to the second principle above. The corresponding head losses in one closed circuit are calculated using the Hazen Williams formula. The head losses are then added considering their signs. This same head loss calculation and addition are done to each of the other closed loops. The assumed flow values are adjusted and the above procedure is done repeatedly until the summation of the head losses in the closed circuit becomes zero. Nowadays, manual computation for hydraulic network analysis is only acceptable when applied to systems with only a single pipeline or branched network with no loop. For networks with loops, it is highly



recommended to use the more accurate, fast and convenient network modelling computer software, which is discussed in the following section.

**2. Network Analysis by Computer Software:** There are a number of pipe network analysis software (also called network simulation software, or hydraulic network modelling software) which mathematically solve hydraulic equations for all interconnections, branches and loops of the pipe network. With the advent of such powerful software, the conventional methods of water distribution design have been mostly discarded. The computer software requires the designer to create a water supply system model by inputting in the computer program information that includes pipe lengths, junction or node elevations, connectivity of the pipes and nodes, demand in each node, information on pumps, elevations of reservoirs, elevations and yield of sources. EPANET Software is among the current software available in the internet and from proprietary sources. WaterCAD is a commercial software for hydraulic analysis and design of water distribution network. EPANET is public domain software developed by the US Environmental Protection Agency that can be downloaded free on the internet. The software tracks the flow of water in each pipe, the pressure at each node, and the height of water in each tank. The important features of EPANET for distribution network design its ability to:

- Handle systems of any size;
- Compute friction head loss using the Hazen-Williams, the Darcy Weisbach, or the Chezy-Manning head loss formula;
- Include minor head losses for bends, fittings, etc.;
- Model constant or variable speed pumps;
- Allow storage tanks to have any shape

. The design process using EPANET usually involves the

(a) layout of the system configuration including locations of sources and storage facilities,

(b) determination of the distribution of demands to the nodes, input of network data, running hydraulic simulation, viewing results in any of the variety of formats, modifying the model by editing the network data, and modifying the model until the design criteria are met or results are acceptable.

**1. Base Mapping:** Detailed maps of the community concerned should be gathered as basis for pipeline alignment, distance and elevations and this can be obtained from Municipal Planning Office . Topographical maps of scale 1:50,000 are usually available in Surveyor General Office. In addition to aerial images of houses, streets, rivers and other objects, spot elevations can be obtained from Google Earth. The information in the maps are correlated to produce a base map, on which the proposed system layout is drawn. The designer should conduct an visual inspection

of the whole project area to verify, validate and update the information on the source maps. The base map developed should include positions and information on roads, streets, rivers, creeks, elevations, topographic contours, locations of built-up areas; it should provide relevant information like large potential consumers. The base map must be scaled.

**2. Water Demand Projection:** The average day demand for the design year is the basis of the hydraulic network analysis. The demand condition will be varied by adjusting the demand factor; that is 1 for the average day demand condition, 1.5 for the maximum day demand and 2.5 – 3 for the peak-hour demand.

**3. Tentative Layout:** Using the base map, the designer should next develop a tentative layout of the pipe network, which should also show the positions of the source facilities and reservoir(s). Pipelines are to be laid on road right of way, and the network should cover the target consumers. Nodes are placed at locations for pipe junctions, street or road junctions and intersections, locations for public faucets, demand centers, and not more than 100 meters from the nearest node. In systems where it is expected that pressure will be generally low or fluctuating, nodes are placed at the highest points of the service area.

**4. Distribution of Demands:** It is important to plot the community boundaries and the service area delineation on the base map. Once the tentative layout (with nodes) is plotted on the base map, the service area should be subdivided into node areas. This will give the designer a working idea of the respective number of houses within the area covered by each node. The projected average day demand for the design year is distributed to all the nodes within its delineated service area. The distribution of demands should take into consideration the relative number of houses for the different node areas.

**5. Encoding of Input Data:** Most of the hydraulic analysis software have common input data requirements. These data are grouped into pipe data and node data. Pipe data are the assigned pipe number, pipe diameter (mm), C-value, the pipe nodes, and length (m). Node data are node number, elevation (m), and water demand (lps). Usually, the values of the design criteria are required by computer software. The design parameters are given in applicable Pipeline design criteria.

**6. Hydraulic Network Simulation:** This step is done by the computer software. If all the data required have been inputted by the designer, the software could proceed with its hydraulic run. The software computes the head losses (m) in each pipe, the rate of head loss (m/km) in each pipe, the flow velocities (m/s), and the pressure in each node (m). The model is run for: (a) its peak-hour demand condition, to check for the possible value of the minimum systems pressure; and (b) its minimum demand condition, to check for the value of the possible maximum pressure in the network.

**7. Examination of Hydraulic Run Results:** Usually all possible hydraulic parameters can be shown from the computer run results. Of these parameters, the designer must examine two

important results very closely: (a) the low system pressure points that are below the 7 m pressure and the affected nodes, and (b) the pipes that have high head loss per km in excess of the 10 m/1,000 m pipeline criteria. The designer must also examine the balancing flows of the reservoir and analyze if the reservoir discharge or inflow are reasonable for its storage size.

**8. Adjusting Assumed Parameters of the Elements:** Based on the results of the computer simulation, the designer will improve the network model by adjusting the pipe and node data for specific elements, particularly for those that did not meet the design criteria. For example, for pipes that have high resulting head losses, the designer will have to increase the pipe size to the next larger diameter. If there is a system pressure that is below 7 m, the designer could replace some of the pipes leading to the affected node with a larger diameter. The height of the reservoir could be adjusted if needed to achieve a good system pressure. The adjusted model is run again in the software. After the run, the results are examined and the model readjusted. The above cycle is done until an acceptable hydraulic model is achieved.

**9. Finalizing the Network Configuration:** The model is subjected to repeated simulation and data adjustments until an acceptable network configuration is reached.

## REFERENCES

- (1) Al-Layla, M.A., Ahmad, S.. and Middlebrooks, E.J. (1978), Water Supply Engineering Design. Ann Arbor Science Publishers Inc.
- (2) Agunwamba, J.C (2008), Water Engineering Systems, DE ADROIT INNOVATION, Enugu
- (3) Hammer, M.J. and Hammer, M.J.(Jr), (2001), Water and Wastewater Technology. Prentice Hall Publishers.
- (4) Environmental Engineering By Ruth F. Weiner and Robin Matthews
- (5) Water Supply Engineering By B.C.Punmia, Ashok Kumar Jain and Arun K. Jain
- (6) Qasim, S.R., Motley, E.M.and Zhu, G.(2006), Water Engineering Works, Prentice Hall of India, New Delhi

(7) Garg, S.K.(1977), Water Supply Engineering. Khanna Publishers.

(8) Viessman, W. and Hammer, Mark. J., Perez, E. and Chadik, P.A. (2011), Water Supply and Pollution Control, PHI Learning Private Ltd, New Delhi.

## MODULE 3

### MODULE 1: INTRODUCTION TO WATER TREATMENT TECHNIQUES

#### Topical Outline

##### 1.0 Introduction

The primary goals of water treatment professionals across the globe is to provide Safe, potable, abundant, and affordable water. No matter how poor the original source of water supply, the finished drinking water that emerges from the consumer's tap must be of high quality free from pathogens.

It must also not contain concentrations of either natural or manmade contaminants in concentrations that could produce adverse health impacts. The aesthetics of drinking water are important since consumers will link the appearance, taste, and odor of the water to its safety. Although the amount of tap water that is actually consumed by humans or used for cooking and food preparation is less than 5 percent that enters the home, all of the water treated must meet these goals for safety and aesthetics. Other non potable uses such as washing, flushing wastes, irrigation, and so on must also meet acceptable standards so the water treatment plant must produce a sufficient quantity of water that meets all these needs. Achieving these objectives at a reasonable and affordable cost is perhaps the greatest challenge facing the water community today.

Water treatment in the twenty-first century accomplishes these goals using a range of principles and practices, some new, some not so modern. The quest for potable water dates as far back as the earliest recorded history.

#### Water quality testing

Clean water is 2 parts hydrogen, 1 part oxygen. In nature, water contains many dissolved impurities. In fact, water is referred to as “the universal solvent” due to its ability to dissolve many substances. Even distilled water and rainfall are not “completely” pure because they usually contain very low levels of dissolved substances such as ammonia, which are considered impurities. There are dissolved substances found in surface and ground water. As rain falls, nitrogen and other gasses are absorbed. Water, as it travels through the ground, can dissolve substances from the earth such as sodium, calcium, iron, phosphorus, magnesium, and sulfate.

When you pour yourself a glass of water to drink, it may appear clean, taste good, and you may expect it to be safe. However, many sources of water we assume are safe may contain dissolved minerals, organic compounds or even live organisms at harmful concentrations. Contaminated water used for drinking and cooking may affect your health. Also, high concentrations of certain minerals in your water can result in quality issues such as unpleasant taste and odors or staining of bathroom fixtures and/or laundry.

The quality of water, whether it is used for drinking, irrigation, or recreational purposes, is significant for health worldwide. The quality and safety of drinking water is of great concern to many today because of an increased interest in health and environmental quality. This new focus on water quality has led many countries to consider testing their water and developing water quality standards. This section of this module, is intended to help you understand water testing and to identify the tests needed.

Water testing is carried out both in a Public Water System and private wells such as boreholes in private residence. Public Water Supply is one that has at least 15 service connections or serves at least 25 people per day for at least 60 days of the year. If you receive drinking water from a

PWS, the source of drinking water is either a surface water reservoir, a public well that pumps groundwater, or both. A system of pipes distributes the water to you and your neighbors. When your home is on a PWS, there are fewer concerns about water quality and safety because they are routinely tested and treated (if needed) for potential contaminants according to standards.

However, for a private well, the owner is responsible for the quality and safety of the well water. Properly constructed and maintained water wells can provide many years of trouble-free service. However, surface contaminants may enter the well if it is not properly constructed and maintained, and the well may eventually deteriorate or become damaged as it gets older. In addition, some groundwater naturally contains one or more chemical substances at levels above the WHO health-based standards. The taste, odor and appearance of your drinking water can give you an indication of its quality, but it does not indicate if the water is really safe or unsafe to drink. Contaminated water can taste and smell fine, whereas unpleasant-tasting or -smelling water can be safe to drink or use. Many of the most serious problems can only be detected through laboratory testing of the water.

### **TYPES OF WATER QUALITY TESTS**

In general, water testing can be classified as bacteriological, mineral/inorganic and organic chemicals tests.

- **Bacteriological tests** generally check for indicator bacteria (for example, total coliform, fecal coliform or *Escherichia coli*) and can indicate the presence or absence of disease-causing bacteria. However, there are many types of bacteriological tests that cover a variety of bacteria. These tests are costly and are conducted only if they are absolutely essential.

- **Mineral tests** can determine if the mineral content of your water is high enough to affect either health or the aesthetic and cleaning capacities of your water. A mineral test may include calcium, magnesium, manganese, iron, copper, zinc and some others. An abundance of these minerals can cause hard water, plumbing and laundry stains, or bad odors.
- **Organic chemicals tests** are generally performed only if there is reason to believe a specific contaminant has infiltrated the water system (such as pesticides entering the water supply). Industrial and petroleum contamination can also be found through organic chemical testing.
- **Other tests** may be conducted on radiological contaminants (radium and radon) or heavy metals (such as arsenic, mercury, lead or cadmium) based on the suspected natural and anthropogenic (man-made) sources of such contaminants.

## **WHEN SHOULD I TEST MY WELL WATER?**

After construction of a new well or when an unused old well is brought back to service, make sure that the water is safe to drink. Consult a drinking water specialist at a water testing laboratory, local health department to get information about the local contaminants of concern. Water quality remains fairly stable if the well is properly constructed and maintained. Even if your current water supply is clean and safe to drink, regular testing is important because it establishes a record of water quality that may help solve future problems. It is also necessary to regularly check the well for potential mechanical problems (improper well construction and/or poor soil filtration). Test the water once each year for total coliform bacteria, nitrates, total dissolved solids and pH levels. If you suspect other contaminants, you should test for those as well.



In contrast, the quality of water in defective wells may change suddenly and remain unnoticed as the water may look, smell and taste the same. More frequent testing and corrective actions may be required.

**You should also consider testing your water if:**

- your well does not meet construction codes, including deteriorated/ damaged well cap, well casing or curbing (concrete slab)
- family members or guests consuming the well water complain of gastrointestinal ailments
- anytime a pregnant woman, woman anticipating pregnancy or infant under the age of six months uses well water for drinking
- you are concerned about the presence of lead pipes or soldering in your home
- your water or pipes show signs of deterioration (e.g., water with a strange color, odor, taste or consistency, or pipes that are corroded or leaking)
- your water stains plumbing fixtures and laundry.
- you notice a water quality change after a heavy rain or an unexplained change in a previously trouble-free well (e.g., funny taste, cloudy appearance, etc.)
- you spill fertilizers, pesticides, oil, gasoline or other toxic substances on the ground within 500 feet of the well or in the well
- you have experienced some problems near your well (e.g., the area around the wellhead has been flooded or submerged, there have been land disturbances or new waste disposal sites nearby)
- you notice a substantial development in your area with land uses that handle hazardous chemicals
- you hear about new contamination problems in your area
- you installed a new treatment system or replaced the main component of the existing one (filter media or cartridge)
- you detected that back-siphoning has occurred due to vacuum break failure or any other reason
- your water or well system has been contaminated or is suspected to have been contaminated by human or animal waste

- you discovered that your (or your neighbor's) septic system absorption field is within 100 feet of your well

**WHICH TESTS SHOULD I REQUEST FOR MY WELL WATER AND HOW OFTEN?**

No single test provides information on all possible contaminants, but water quality can be determined by the right test(s). Some contaminants, called primary contaminants, can be a health risk if present in concentrations above the primary Maximum Contaminant Level (MCL). These include microorganisms such as bacteria, viruses or protozoa; inorganic chemicals such as arsenic, lead or nitrate; and organic chemicals such as insecticides, herbicides, fuel and solvents. Some contaminants, while not a health risk, can affect acceptability of water for domestic use if their concentrations exceed the secondary MCL. Given the long list of potential water contaminants, it may be cost prohibitive and in most cases unnecessary to test for all of them.

Table 1 lists the water tests appropriate for some common situations; Table 2 summarizes some common water quality concerns, their causes and relevant water testing; and Table 3 includes some unique situations and required water testing. These tables are just guidelines and do not replace the need for an expert opinion from a water specialist. Consult an expert if you suspect any contaminant that could present an immediate or long-term health risk.

Testing Objective	Type of Test	Testing Frequency
Minimum Testing Recommendations		
Well Maintenance	<b>Bacteria</b>	Annual
	Nitrates (Total Nitrate and Nitrate + Nitrite)	Annual
	<b>Turbidity and Colour</b>	Annual

	<b>Comprehensive Water Chemistry:</b> Basic Water Chemistry, Alkalinity, Soluble salts rt TDS, Nitrate, Chloride, Fluoride and Sulphate	Initially and then every 3 years
	<b>Basic Water Chemistry:</b> pH, Hardness, Calcium, Iron, Copper, Manganese and Zinc	Annually after initial comprehensive water chemistry
<b>Additional Testing Recommendations</b>		
Verification of Potential Contamination	<b>Lead and Copper</b>	At least once, then yearly follow up
	<b>Arsenic</b>	At least once, then yearly follow up
	<b>Uranium</b>	At least once, then yearly follow up
	Volatile and Semi-volatile Organic Compounds, Pesticides, Petroleum Hydrocarbons and Other Organics	Not required on a regular interval; recommended only when contamination is suspected.

Table 1: Generally recommended water test

Table 2: Water quality concerns, common signs, causes and recommended test(s).

Other	Corrosion of plumbing materials	Corrosive water	pH, Hardness, Alkalinity, Saturation Index, Lead, Copper, Iron, Manganese, Sulfate, Chloride and Electrical Conductivity
	White deposits on bathroom fixtures and pots or soap scum	Hard water	pH, Hardness, Alkalinity, Sulfate and Electrical Conductivity (or Total Dissolved Solids)
	Tarnished silverware	Hydrogen sulfide gas	pH and Hydrogen Sulfide
	Gastrointestinal illness (e.g., stomach ache, nausea, diarrhea)	Bacterial contamination, presence of excess nitrate, sulfate and manganese	Bacteria, Nitrate, Sulfate, Manganese, Detergents
	Discoloration and/or mottling of children's teeth	Excessive fluoride	Fluoride
	Black	Dissolved manganese, hydrogen sulfides	pH, Manganese and Hydrogen Sulfide
	Green or blue	Corrosive water, dissolved copper	pH, Hardness, Alkalinity, Saturation Index and Copper
Abnormal odor or taste	Bitter	Dissolved nitrate or sulfate	Nitrate and Sulfate
	Rotten egg	Hydrogen sulfide	Hydrogen Sulfide
	Soapy	Detergents, surfactants	Detergents and Total Anionic Surfactants
	Metallic	Dissolved metals like iron, manganese zinc, copper, lead	pH, Iron, Manganese, Zinc, Copper and Lead
	Salty	Excessive soluble salts	Total Dissolved Solids, Chloride,
	Septic, musty, earthy	<ul style="list-style-type: none"> <li>• Decaying organic matter in the drain</li> <li>• Pollution of well water from surface drainage</li> <li>• Bacteria in the drain and/or well</li> </ul>	Bacteria, pH
	Gasoline, kerosene, oil	Contamination by petroleum hydrocarbons, oil and grease	Petroleum Hydrocarbons, Oil and Grease
	Fruity	Fuel spill, leaking underground fuel storage tank, road runoff, ponding near well	Volatile Organic Compounds

Table 3: Situation-specific water test recommendations.

Situation	Test(s) to be Considered
Water supply for infant less than 6 months, pregnant or nursing woman, or elderly person with a genetically impaired enzyme system	Nitrate
Water supply used for children under 12 with developing teeth buds	Fluoride
Lead pipe or lead solder in plumbing (older home)	Lead, Copper, Zinc, pH, Hardness, Alkalinity
Close to old fuel storage tanks	Petroleum Hydrocarbons, Volatile Organic Compounds
Close to gas and oil drilling	Chloride, Total Dissolved Solids, Sodium, Barium, Lead, pH, Electrical Conductivity, Volatile Organic Compounds
Close to confined livestock area	Nitrate, Coliform Bacteria
Close to a chemical/pesticide spill or sprayer loading/rinsing area	Specific Chemical or Pesticide
Close to a landfill or dump site	Volatile Organic Compounds, Heavy Metals, Synthetic Organic Compounds
Septic system failure	Coliform Bacteria, Nitrate, Detergents, Total Dissolved Solids, Chloride, Sodium, Sulfates
Well located within an area of intensive agricultural use	Coliform Bacteria, Nitrate, Pesticide Scan, pH, Total Dissolved Solids
<ul style="list-style-type: none"> <li>• Well near the coast or a salt storage pile</li> <li>• High blood pressure in the family</li> <li>• Water softener in place</li> </ul>	Sodium, Chloride, Total Dissolved Solids

Adapted from “Water Quality Series: Drinking Water Testing,” Oklahoma Cooperative Extension Service AGCE-878.

**HOW SHOULD I TAKE A WATER SAMPLE FOR TESTING?**

- Samples collected from the wellhead would allow evaluation of source water properties and designing any treatment system that may be necessary.
- Samples collected from a kitchen faucet would reflect the source water properties plus any potential contamination from the well owner’s water supply system. For example, sampling at the wellhead for lead is not necessary, but sampling from the faucet for lead would indicate if lead solder was used in the plumbing. Also, it can indicate the efficiency of an existing treatment system.

**WHERE SHOULD I TEST MY WELL WATER?**

Accredited water testing laboratory can provide you the necessary information about sampling procedure, type of container, any preservative(s) necessary and shipping method.

### **HOW ARE THE WATER TEST RESULTS INTERPRETED?**

Some contaminants are reported in parts per million (ppm) or milligrams per liter (mg/L); others in parts per billion (ppb) or micrograms per liter ( $\mu\text{g/L}$ ). Bacteria in water are generally reported as Most Probable Number (MPN) or Colony Forming Units (CFU) per 100 mL. The presence of a contaminant is not always an indication of a health hazard or a serious nuisance. The level at which it is found is most important. Interpretation of the test results requires knowledge of the Maximum Contaminant Levels (MCLs) established under the relevant safe drinking water standards. The concentration of a contaminant above its MCL merits attention and action to reduce it below the MCL. The primary MCLs have been set at concentrations that provide a wide margin of protection from harmful health effects for most people over a lifetime of drinking. Even though primary MCLs are enforceable standards for PWSs only, private well owners may choose to follow these standards to protect themselves from the potential health risk of drinking contaminated water.

### **Common Water Quality Terms/Parameters**

**Aesthetic Objective (AO)** - levels of substances or characteristics of water that can affect its acceptance by consumers, cause problems with water distribution systems and fixtures, or interfere with practices for supplying good quality water. They are not health related guidelines but are related to aesthetic aspects of the water.

**Alkalinity** - is not a specific substance but rather a combined effect of several substances. It is a measure of the resistance of water to a change in pH. The alkalinity of most prairie waters is in the range of 100 to 500 mg/L, which is considered acceptable. Water with higher levels is often used. Alkalinity is a factor in corrosion or scale deposition and may affect some livestock when over 1,000 mg/L.

**Calcium and Magnesium** - are elements of "hardness" in water. They are not hazardous to health but are undesirable because they may cause problems for domestic uses such as washing, bathing and laundering. It causes encrustations in kettles, coffee makers, and water heaters. It can also foul some water treatment systems such as distillers and reverse osmosis units.

**Coliforms, Fecal** - Fecal Coliforms are a general indicator of contamination from an animal or human source. Its presence in water indicates that the water has been contaminated by faeces of humans or other animals and the possible presence of intestinal disease-causing bacteria. They are a more general indicator than E. Coli. Fecal Coliforms are also useful indicators of the possible presence of viruses and protozoa.

**E. Coli (Escherichia coli)** - E. coli is a member of the total coliform group of bacteria and is the only member that is found exclusively in the faeces of humans and other animals. Its presence in water may indicate not only recent faecal contamination of the water but also the possible presence of intestinal disease-causing bacteria.

**Coliforms, Total** - The presence of these bacteria may indicate contamination in a water supply. This group of bacteria is found in feces, soil, and vegetation and is used as an indicator of the bacteriological quality of water. Coliforms are useful indicators of the possible presence of pathogenic bacteria and viruses.

**Conductivity (E.C.)** - is measured in decisiemens/meter (dS/m). It can be used to estimate the total dissolved solids in the water. Multiplying the conductivity in dS/m by 640 will give a good approximation of the total dissolved solids in mg/L. Conductivity tests are often used to assess water suitability for irrigation. Conductivity is sometimes expressed as microSiemens/cm ( $\mu\text{S}/\text{cm}$  OR  $\text{uS}/\text{cm}$ ), which is 1000 times smaller as a unit than deci siemens per centimeter. (Eg  $0.75 \text{ decisiemens}/\text{m} = 750 \text{ microsiemens}/\text{cm} = 0.750 \text{ millisiemens}/\text{cm}$ ). We have used the letter "u" within our tool to represent the "micro" prefix " $\mu$ ". We have used the conversion of  $1 \text{ dS}/\text{m} = 700 \text{ mg}/\text{L}$  TDS within the tool because the federal guidelines have used this conversion for their guideline values for TDS.

**Fluoride** - occurs naturally in most groundwater wells and can help prevent dental cavities. As fluoride levels increase above the guideline, there is an increase in the tendency to cause tooth mottling.

**Hardness** - causes excessive soap consumption and scaling. Hardness is caused primarily by calcium and magnesium, but is expressed in terms of an equivalent of calcium carbonate. Hard



water causes soap curd, which makes bathroom fixtures difficult to keep clean and causes greying of laundry. Hard water will also tend to form scale in hot water tanks, kettles, piping systems, etc. It can also foul some water treatment systems such as distillers and reverse osmosis units.

**Iron** - levels as low as 0.2 to 0.3 mg/L will usually cause the staining of laundry and plumbing fixtures. The presence of iron bacteria in water supplies will often cause these symptoms at even lower levels. Iron gives water a metallic taste that may be objectionable to some at 1 to 2 mg/L. Most water contains less than 5 mg/L iron, but occasionally, levels over 30 mg/L are found.

**Maximum Acceptable Concentration (MAC)** - level of a substance that is known, or suspected to, cause adverse effects on health.

**NO<sub>3</sub> nitrogen (Nitrate)** - higher levels are often an indicator of contamination by human or livestock wastes, excessive fertilization or seepage from dump sites. The maximum acceptable concentration in drinking water is 10 mg/L. This figure is based on the potential for nitrate poisoning of infants. Adults can tolerate higher levels, but high nitrate levels may cause irritation of the stomach and bladder. The suggested maximum for livestock use is 100 mg/L. Nitrate is converted to nitrite in the body. Nitrite causes asphyxiation by entering the bloodstream and reacting with hemoglobin (the red, oxygen-carrying pigment of the blood) to form

methemoglobin, which is not able to carry oxygen to the body's tissue. Nitrate in water is approximately 10 times more soluble than in feed. Caution is needed to differentiate between nitrate and nitrate-N or nitrate as N (where only the amount of nitrogen occurring in the Nitrate is reported).  $\text{Nitrate} = \text{Nitrate-N} * 4.4$ . Nitrates can also occur naturally in groundwater at lower levels.

**NO<sub>2</sub> nitrogen (Nitrite)** - has an element of toxicity. If sampled correctly, nitrite is usually an indicator of direct contamination by sewage or manure because nitrites are unstable and can quickly be transformed into nitrates suggesting that a current and ongoing source of fecal contamination is present. Nitrates and nitrites are considered together in water analysis interpretation. The conversion of the nitrogen ion as compared to the nitrogen component within the nitrite ion (Nitrite-N) is approximately  $\text{Nitrite} = \text{Nitrite-N} * 3.28$ .

**pH** - expresses the intensity of the acid or alkaline condition of a solution. A pH of 7 indicates neutral conditions on a scale of 0 (acidic) to 14 (alkaline). The generally accepted range for pH in water is 6.5 to 8.5 with an upper limit of 9.5.

**Sodium** - is not considered a toxic metal. 5,000 to 10,000 milligrams per day are consumed by normal healthy adults without adverse effects. The average intake of sodium from water is usually only a fraction of that consumed in a normal diet. People suffering from certain medical

conditions such as hypertension may require a sodium restricted diet, in which case the intake of sodium from drinking water could be significant. Sodium is a significant factor in assessing water for irrigation and plant watering. High sodium levels affect soil structure and a plant's ability to take up water.

**Sulphate (SO<sub>4</sub>)** - concentrations over 500 mg/L can be a laxative to some humans and livestock. Sulphate levels over 500 mg/L may be a concern for livestock receiving marginal intakes of certain trace minerals. Very high levels of sulphates have been associated with some brain disorders in cattle and pigs.

**Total Dissolved Solids (TDS)** - comprise inorganic salts and small amounts of organic matter that are dissolved in water. The principal constituents are usually the cations calcium, magnesium, and sodium, and the anions carbonate, bicarbonate, sulphate, chloride, and nitrate.

**Turbidity** - is a measurement of particles of matter suspended in water. These particles can be clay, silt, finely divided organic and inorganic matter, plankton and other microscopic organisms. Turbidity is a measurement of how light scatters when it is aimed at water and bounces off the suspended particles. It is not a measurement of the particles themselves. In general terms, the cloudier the water, the more the light scatters and the higher the turbidity. The treated water turbidity target is 0.1 NTU (nephelometric turbidity units). Turbidity as a secondary indicator of

suspended solids and is a common measurement made in surface water. It is used to determine the likely effectiveness of some disinfection processes such as ultraviolet light or chlorination that require direct exposure to the target contaminant.

### **Choosing a Water Treatment System**

(For Private Water and Health Regulated Public Water Supplies)

When choosing a water treatment system there are a number of factors to be considered: size of treatment system, type of contaminants you want to treat, knowledge of how the proposed treatment system works including its strengths and weaknesses, purchase price and maintenance costs, and whether or not the water treatment device is safe and effective.

#### **Step One: Decide How Much Treated Water You Want**

Home water treatment systems or devices come in two basic sizes: point-of-entry (POE) and point-of-use (POU). Point-of-entry devices treat all water entering the home and are typically connected to the main water line. Point-of-entry devices treat about 100 –300 gallons per day depending on the number of household users.

Point-of-use water treatment devices treat only water for drinking and cooking and are typically installed near a kitchen or bathroom tap either above or below the counter top. Point-of-use devices only treat a few gallons of water per day.

#### **Step Two: Identify the Contaminates You Want to Treat**

When choosing a water treatment system, it is important to keep in mind that water quality can fluctuate over short periods of time. Fluctuations in the concentration of various constituents can occur for a variety of reasons such as but not limited to the length of prior pumping, height of groundwater table, rainfall timing and amount, and season of the year. Before choosing a water treatment system, it is recommended that a minimum of two trials of water quality tests for bacteria and chemical constituents be taken over a period of months to gain information on contaminant levels within your source water. Water quality testing may identify your parameters of concern. Treatment goals that should be considered are:

1. Remove parameters of concern as identified from the tests to levels below the maximum acceptable concentration as defined by relevant standards.
2. Complete disinfection for bacteriological contaminants (such as E.Coli or Total Coliforms)
3. Removal/inactivation of 99.9% of cysts (such as Cryptosporidium and Giardia Lamblia).
4. Removal/inactivation of 99.99% of viruses

### **Step Three: Do Your Homework When Selecting a Water Treatment System**

The type of water treatment system to be chosen will depend greatly on the number and type of contaminants or aesthetic problems identified by the water quality tests completed on your source water. Once you have determined the parameters of concern in your water, it is best to contact as many water treatment experts as possible to find out about the water treatment options

that are available. When discussing water treatment options with a local water treatment expert, the following questions should be considered:

- What treatment options are used to treat specific water quality problems?
  - How do these specific treatment options work?
  - What other treatment options are available?
  - What specific equipment/device that will perform this treatment is recommended?
  - Why?
  - Can the treatment device be connected to additional treatment devices in the future for increasing capacity or further improving treatment?
  - What treatment options are being used in the area with similar water quality problems?
  - What disadvantages are common to the treatment device being considered?
  - What are the installation and maintenance costs associated with the treatment devices?
- 
- Does the treatment option involve adding chemicals to the water? If yes, what are they?
  - How many treatment steps are needed? (eg. pre-filtration -> cartridge filtration -> UV disinfection)
  - In what ways can the treatment device malfunction and how can these malfunctions be detected?
  - What maintenance requirements are needed to ensure the treatment device operates efficiently? (eg. Replacing filters, cleaning components, etc.)

#### **Step Four: Recognize Water Treatment Devices Have Limitations**

While there are many water treatment devices available, there is not one that can perform every kind of treatment. When dealing with multiple contaminants and aesthetic problems, it is important to identify those of greatest concern and make sure you choose the appropriate treatment technology (Table 4 and 5). Under different water quality conditions, a listed treatment technology may perform to different levels of effectiveness. In some cases, it may be necessary to have more than one treatment device to meet your water quality needs. Table 1 and 2 are not

complete lists of contaminants and treatment processes; therefore, you should make certain that the treatment components selected remove your contaminants of concern.

Treatment Technology	CONTAMINANT										
	Arsenic	Copper	Lead	Other Heavy Metals	Fluoride	Nitrate	SOCs	Radium	Selenium	Uranium	Microbia
Activated Alumina	R			PR	R				R	R	
Granular Activated Carbon				PR			R				
Distillation	R	R	R	R		R					R
Anion Exchange	R			PR		R			R	R	
Cation Exchange		R	R	PR				R			
Ozonation											R
Reverse Osmosis	R	R	R	R	R	R	R	R	R	R	R
Other Adsorption Media	R										
Electrodialysis				R	R	R					
Cartridge Filter											some Protozoa only
Ultra Violet Light											R

Table 4: Applicability of POE and POU Treatment Technologies to Contaminant Removal

- SOC's are Synthetic Organic Chemicals; R = Treatment technology may remove the noted contaminant; PR = Treatment technology may be only partially effective at removing some portion of the contaminant under limited conditions.

Other adsorption media include iron-, aluminum-, or titanium-dioxide-based media.

- Cation and anion exchange where a filter bed removes a particular parameter by exchanging the substance with one in the resin. A common example is the removal of calcium and magnesium by exchanging with sodium in a cation exchange resin found in typical water softeners.

Treatment Technology	CONTAMINANT
----------------------	-------------

	Hardness	Hydrogen Sulphide	Iron/Manganese	Sodium	TDS	Chlorine	Colour	Taste and Odour	Turbidity
Activated Alumina									R
Granular Activated Carbon		R				R	PR	R	R
Distillation	R		R	R	R	R	R	R	R
Ion Exchange	R		PR	PR					
Ozonation							R	R	
Reverse Osmosis	PR		PR	R	R	R	R	R	R
Electrodialysis			PR	PR	PR				
Cartridge Filter			PR				PR		PR

Table 5: Applicability of POE and POU Treatment Technology to Improving Aesthetics

- TDS = Total dissolved solids;
- R = Treatment technology may remove the noted contaminant; S = Treatment technology may be only partially effective at removing some portion of the contaminant under limited conditions.
- Ion exchange includes greensand and potassium permanganate treatment

### Step Five: Consider the Long-Term Costs

When deciding to purchase a water treatment device or system, one should consider the long-term costs associated with maintenance and operation. Nearly all water treatment systems require some type of regular maintenance such as replacing clogged filters, removing built up water scale or sanitizing the water treatment unit.

Furthermore, the cost of operation for some treatment systems may be a lot less than others. Knowledge of the maintenance and operational costs (eg. backwashing volumes, wastewater disposal, chemical usage, etc.) allows one to make practical decisions when purchasing a water treatment device.

### Step Six: Look for Certification



When purchasing a water treatment device look for information indicating that it is certified for the specific purpose for which it will be used. Certification indicates a product is safe and effective and can perform to standards as established by the standardization body.

## REFERENCES

Alberta Health and Wellness, Environmental Public Health Field Manual for Private, Public and communal Drinking Water Systems in Alberta  
Second Edition 2004.

.AquaVic Water Solutions Inc. (2007). Application of “Point of Entry” and “Point of Use” Water Treatment Technology in British Columbia.  
[http://www.health.gov.bc.ca/protect/poureport\\_main.pdf](http://www.health.gov.bc.ca/protect/poureport_main.pdf)

DeSimone, L.A., P.A. Hamilton, R.J. Gilliom. 2009. “Quality of Water from Domestic Wells in Principal Aquifers of the United States, 1991–2004.” USGS NAWQA Scientific Investigations Report 2008-5227. <http://water.usgs.gov/nawqa/>

DeSimone, L.A., P.A. Hamilton, R.J. Gilliom. 2009. Quality of water from domestic wells in principal aquifers of the United States, 1991-2004–Overview of major findings: U.S. Geological Survey Circular 1332, 48 p. <http://pubs.usgs.gov/circ/circ1332/>

.Frankenberger, J. and C. Janssen. 1990. Why & How to Test Home Water Supplies. Purdue Extension.

New Hampshire Department of Environmental Services. (2005). Considerations When Purchasing Water Treatment Equipment.  
<http://www.des.state.nh.us/factsheets/ws/inc/2-5.html>

“Residential Well Water Testing. Private Well Program.” State of Connecticut Department of Public Health.

Skipton, S., B. Dvorak and W. Woldt. 2005. G89-907 Drinking Water: Testing for Quality. University of Nebraska – Lincoln Extension

“Testing for Water Quality.” University of Georgia Cooperative Extension.

U.S. Environmental Protection Agency. (2006). Point-of-Use or Point-of-Entry Treatment Options for Small Drinking Water Systems  
[http://epa.gov/safewater/smallsys/pdfs/guide\\_smallsystems\\_pou-poe\\_june6-2006.pdf](http://epa.gov/safewater/smallsys/pdfs/guide_smallsystems_pou-poe_june6-2006.pdf)

“Water Quality Testing for Private Wells in New Hampshire.” New Hampshire Department of Environmental Services, Concord, NH.

## MODULE 3

### **1.0 Water treatment process**

#### **1.1 Introduction**

It is essential that the design of any treatment process is based on a full investigation of site conditions, including chemical and microbiological analysis of the water to be treated, a risk assessment and the results of laboratory or pilot scale tests to determine the effectiveness of the process and the chemical dosing requirements. This module shall provide an overview of the basic principles of water treatment; anyone planning to install or upgrade a water treatment process should seek expert guidance.

Where water is used for any domestic purposes it must be wholesome. Requirement for treatment may vary according to rainfall, catchment activity or other reasons. Although monitoring may indicate that the water is bacteriologically safe some of the time, it is extremely likely that there will be a bacteriological challenge at other times. In practice this means that many supplies will require a disinfection stage unless the supply can be shown by risk assessment and frequent surveillance to be likely to be consistently pathogen free.

A range of water treatment processes is covered here. For some contaminants, potentially several techniques could be appropriate. For example, membrane processes can remove a broad spectrum of contaminants but cheaper and simpler alternatives may be just as effective in particular cases. It is likely that a combination of processes will be required to deal with the majority of waters, for example filtration followed by UV to remove particles and inactivate microorganisms.

#### **1.2 Multiple barriers**

Virtually all water sources require treatment prior to consumption to ensure that they do not present a health risk to the user. Health risks from poor quality water will often be due to microbiological or chemical contamination. Absence of microbiological contamination is generally the most important to human health as pathogens can lead to infectious diseases. Chemical contamination, with the exception of a few substances such as cyanide, tend to represent a longer term health risk. Substances in water which affect its appearance, odour or taste may make water objectionable to consumers and lead to rejection based on aesthetics. As microorganisms can be associated with particles and turbidity in water, physical contamination may also represent a health risk as it makes disinfection more difficult. Most treatment systems are designed to remove microbiological contamination and those physical constituents, such as suspended solids (turbidity) that affect aesthetic acceptability or prevent effective disinfection. A final disinfection stage is nearly always included at the end of the treatment process to inactivate any remaining microorganisms. When a persistent disinfectant, such as chlorine, is applied this also provides a residual that will act as a preservative to prevent biological regrowth during storage and/or distribution in larger systems. Treatment processes are based on the physical removal of contaminants through filtration, settling (often aided by some form of chemical addition) or biological removal of microorganisms. Usually, treatment consists of a number of stages, with initial pre-treatment by settling or pre-filtration through coarse media, filtration followed by chlorination. This is called the multiple barrier principle.

The multiple barrier approach is an important concept as it provides the basis for effective treatment of water and allows each individual process stage to treat water to a suitable quality for

subsequent downstream processes (e.g. filtration can prepare water to ensure it is suitable for UV disinfection). Effective treatment of a supply does not therefore rely on one key stage or process. The multiple barrier principle applies throughout the supply from catchment all the way to the consumer's tap. Proper selection and protection of water sources are of prime importance in the provision of safe drinking water. The subsurface is often an effective medium for attenuating contaminants present in the catchment while the design and good maintenance of the well, borehole, spring or intake can help exclude localised pollution from surface runoff. It is always better to protect water from contamination than to treat it after it has been contaminated. Effective source protection, careful choice of aquifer or water intake and well designed and maintained abstraction structures all constitute effective barriers in the multiple barrier principle.

### **1.3 Coagulation and flocculation**

Coagulation and flocculation are used to remove colour, turbidity, algae and other microorganisms from surface waters. The addition of a chemical coagulant to the water causes the formation of a precipitate, or floc, which entraps these impurities. Iron and aluminium can also be removed under suitable conditions. The floc is separated from the treated water by sedimentation and/or filtration, although flotation processes may be used in place of sedimentation.

The most commonly used coagulants are aluminium sulphate and ferric sulphate, although other coagulants are available. Coagulants are dosed in solution at a rate determined by raw water quality near the inlet of a mixing tank or flocculator. The coagulant is rapidly and thoroughly dispersed on dosing by adding it at a point of high turbulence. The water is allowed to flocculate and then passes into the sedimentation tank (sometimes known as a clarifier) to allow

aggregation of the flocs, which settle out to form sludge. This sludge will need to be periodically removed.

The advantages of coagulation are that it reduces the time required to settle out suspended solids and is very effective in removing fine particles that are otherwise very difficult to remove. Coagulation can also be effective in removing many protozoa, bacteria and viruses.

The principal disadvantages of using coagulants for treatment of small supplies are the cost and the need for accurate dosing, thorough mixing and frequent monitoring. Coagulants need accurate dosing equipment to function efficiently and the dose required depends on raw water quality that can vary rapidly. The efficiency of the coagulation process depends on the raw water properties, the coagulant used and operational factors including mixing conditions, temperature, coagulant dose rate and pH value. The choice of coagulant and determination of optimum operating conditions for a specific raw water are normally determined by bench scale coagulation tests.

Thus, while coagulation and flocculation are the most effective treatment for removal of colour and turbidity they may not be suitable for small water supplies because of the level of control required and the need to dispose of significant volumes of sludge.

#### **1.4 Sedimentation**

Simple sedimentation (i.e. unassisted by coagulation) may be used to reduce turbidity and solids in suspension. Sedimentation tanks are designed to reduce the velocity of flow of water so as to permit suspended solids to settle under gravity. There are many different designs of tanks and selection is based on simple settlement tests or by experience of existing tanks treating similar waters. Without the aid of coagulation, these will only remove large or heavy particles, and due

to the length of time this process will take, the system will usually require storage tanks to balance peaks and troughs in demand.

Sedimentation tanks are usually rectangular with length to width ratios between 2:1 and 5:1. The depth of the tank is usually between 1.5 and 2.0m. The inlet and outlet must be at opposite ends of the tank. The inlet should be designed to distribute the incoming flow as evenly as possible across the tank width and to avoid streaming which would otherwise reduce sedimentation efficiency. Baffles may be installed to prevent short circuiting. The outlet should be designed to collect the clarified water over the entire tank width. The tank should be covered to prevent contamination and ingress. Sedimentation tanks require cleaning when performance deteriorates. This will not normally be more frequent than once per year.

## **1.5 Filtration**

Turbidity and algae are removed from raw waters by screens, gravel filters, slow sand, rapid gravity filters or cartridge filters. The difference between slow and rapid sand filtration is not a simple matter of the speed of filtration, but in the underlying concept of the treatment process. Slow sand filtration is essentially a biological process whereas rapid sand filtration is a physical treatment process. Many small private water supplies will rely on cartridge filters consisting of a woven or spun filter within a standard housing.

### **1.5.1 Screens**

Screens are effective for the removal of particulate material and debris from raw water and are used on many surface water intakes. Coarse screens will remove weeds and debris while band screens or microstrainers will remove smaller particles including fish and may be effective in removing large algae. Microstrainers are used as a pre-treatment to reduce solids loading before coagulation or subsequent filtration. A microstrainer may consist of a rotating drum fitted with

very fine mesh panels, or may be a fixed mesh that the water flows through. The mesh will ensure that suspended solids, including algae, are retained. The extent of solids removal will be determined by the mesh size and the nature of the raw water. Water will need subsequent treatment downstream and screens should only be considered as a preliminary treatment stage.

### **1.5.2 Gravel filters**

Gravel filters may be used to remove turbidity and algae. A simple gravel filter for the protection of a stream or river inlet is described in Section 3.3.1. A larger gravel filter may consist of a rectangular channel or tank divided into several sections and filled with graded gravel (size range 4 to 30mm). The raw water enters through an inlet distribution chamber and flows horizontally through the tank, encountering first the coarse and then the finer gravel. The filtered water is collected in an outlet chamber. Solids removed from the raw water accumulate on the floor of the filter. Gravel filters can operate for several years before cleaning becomes necessary. The size of a gravel filter will depend on water quality, flow rate and size of gravel. A filter can be up to 12m long, 2 to 5m wide and 1 to 1.5m deep. The filter should normally be sized for a flow rate of between 0.5 to 1.0 cubic metres per square metre of filter surface area per hour ( $m^3/m^2.h$ ). A gravel filter will need subsequent treatment downstream, and should only be considered as a preliminary treatment stage.

### **1.5.3 Slow sand filters**

Slow sand filters, sometimes preceded by microstrainers or coarse filtration, are used to remove turbidity, algae and microorganisms. Slow sand filtration is a simple and reliable process and is therefore often suitable for the treatment of small supplies provided that sufficient land is available. Slow sand filters usually consist of tanks containing sharp sand (size range 0.15-0.30mm) to a depth of between 0.5 to 1.5m. For small supplies, modular units of 1.25m diameter



are available – a tandem installation would occupy a concrete apron of about 8 to 10 m<sup>2</sup>. The raw water flows downwards and turbidity and microorganisms are removed by filtration in the top few centimetres of the sand. A biological layer of sludge, known as the *schmutzdecke*, develops on the surface of the filter that can be effective in removing microorganisms. Treated water is collected in underdrains or pipework at the bottom of the filter. The top few centimetres of sand containing the accumulated solids are removed and replaced periodically. Filter runs of between 2 and 10 weeks are possible, depending on raw water quality and flow rate. Slow sand filters are often operated in tandem; one in service whilst the other is cleaned and time allowed for the *schmutzdecke* to re-establish. A variant of the slow sand filter, the “Inverness filter”, has been widely used in Scotland. It uses the same grade of sand and operates at the same flow rate as the traditional slow sand filter but the water flows upwards. Filtration is achieved throughout the filter bed and a true *schmutzdecke* does not develop. The sand is “washed” by opening a valve at the bottom of the filter and allowing the filter bed to drain rapidly.

Slow sand filters should be sized for a water flow rate of between 0.1 and 0.3 m<sup>3</sup>/m<sup>2</sup>.h. The flow rate should be controlled and the filter designed with a treated water reservoir of sufficient capacity to accommodate fluctuations in demand, and thus permit operation of filters at a steady and continuous rate.

#### **1.5.4 Rapid gravity filters**

Rapid gravity filters are most commonly used to remove floc from coagulated waters. They may also be used to remove turbidity, algae and iron and manganese from raw waters. Granular activated carbon media may be used to remove organic compounds.

Rapid gravity sand filters usually consist of rectangular tanks containing silica sand and/or anthracite media (size range 0.5 to 1.0 mm) to a depth of between 0.6 and 1.0m. The water flows

downwards and solids become concentrated in the upper layers of the bed. Treated water is collected via nozzles in the floor of the filter. The accumulated solids are removed periodically by backwashing with treated water, usually preceded by scouring of the media with air. Frequency of backwashing depends on loading rate and raw water quality and is typically every 24 hours. Backwashing can be initiated automatically after a predetermined headloss has been reached or may be carried out manually. Backwash flowrates will be stipulated by the manufacturer. It is important to achieve the required bed expansion in order to ensure filters are washing properly, but care must be taken to prevent loss of media with too high a flowrate. A dilute sludge that requires disposal is produced which may be discharged to sewer, soak away, or after treatment, to a watercourse provided that any required discharge consent is obtained

#### **1.5.5 Pressure filters**

Pressure filters are sometimes used where it is necessary to maintain hydraulic head in order to eliminate the need for additional pumping. The filter bed is enclosed in a cylindrical shell. Small pressure filters capable of treating up to approximately 15m<sup>3</sup>/h can be manufactured in glass reinforced plastics. Larger pressure filters are manufactured in specially coated steel. Operation and performance are generally as described for the rapid gravity filter (see Section 5.5.4) and similar facilities are required for backwashing and disposal of the dilute sludge. A similar range of contaminants can be removed depending on the filter medium.

### **1.6 Aeration**

Air stripping is used for removal of volatile organics (e.g. solvents), carbon dioxide, disinfection by-products, some taste and odour causing compounds, and radon (Section 7.1). It is a fairly specialist technique, and not commonly found as a treatment process on private water supplies,

although aeration can sometimes be found in the oxidation stage of the treatment process for the removal of iron and manganese (Section 7.7.2)

Aeration processes are designed to achieve efficient mass transfer of oxygen into water and removal of gases and volatile compounds by air stripping. Oxygen transfer can usually be achieved using a simple cascade or diffusion of air into water, without the need for elaborate equipment. Stripping of gases or volatile compounds, however, may require specialised plant that provides a high degree of mass transfer.

For oxygen transfer, cascade or step aerators are designed so that water flows in a thin film to achieve efficient mass transfer. Cascade aeration may introduce a significant headloss; design requirements are between 1.0 and 3.0m to provide a loading of 10 to 30m<sup>3</sup>/m<sup>2</sup>.h. If such headloss is unacceptable the alternative is to use compressed air diffused through a system of submerged perforated pipes. These types of aerator are used for oxidation and precipitation of iron and manganese.

To achieve air stripping various techniques can be used including counter current cascade aeration in packed towers, diffused aeration in basins and spray aeration. Packed tower aerators are most commonly used because of their high energy efficiency and compact design.

## **1.7 Chemical treatment**

### **1.7.1 Control of pH**

The pH value of water may need to be adjusted during treatment and before distribution for several reasons, including:

- to ensure that the pH value meets the water quality standards
- to control corrosion in the distribution system and consumers' installations or to reduce plumbosolvency

- to improve the effectiveness and efficiency of disinfection
- to facilitate the removal of iron and manganese
- to facilitate the removal of colour and turbidity by chemical coagulation
- For removal of hardness
- For removal of other contaminants including some metals

Many raw surface waters are slightly acidic and coagulation processes further increase acidity.

Increase of pH can be achieved by:

- dosing with sodium hydroxide, calcium hydroxide or sodium carbonate
- passage of the water through a bed of alkaline medium
- removal of excess carbon dioxide by aeration

Where necessary, reduction of pH can be achieved by dosing with a suitable acid such as sulphuric acid, hydrochloric acid, sodium hydrogen sulphate or carbon dioxide.

### **1.7.2 Iron and manganese removal**

In groundwater, iron is usually present as dissolved ferrous compounds. To remove iron in this form, it is necessary to oxidise ferrous iron, usually by aeration, to the insoluble ferric hydroxide and to remove the precipitated material in a subsequent filtration stage. It is important to ensure that oxidation does not give rise to colloidal species which may pass through the filters. If the iron is present as an organic complex, a strong oxidant such as chlorine or potassium permanganate must be used. Manganese is usually present as dissolved manganous compounds. Removal is achieved by oxidation to insoluble manganese dioxide using catalytic filters or potassium permanganate followed by filtration, or by coagulation at high pH followed by filtration.

In surface waters, iron and manganese are usually present in their oxidised forms and are associated with the suspended solids, which can be removed by filtration. Where coagulation is practised for the removal of colour and turbidity, iron removal may be achieved simultaneously. Iron and manganese may be combined with organic matter in very stable forms. The usual treatment in this case is coagulation followed by oxidation with chlorine or potassium permanganate and filtration.

There are a number of proprietary systems on the market which will oxidise and filter iron and manganese within a single unit with automated control systems.

### **1.7.3 Taste and odour removal**

Taste and odour can be removed by several methods, including aeration, ozonation and adsorption on activated carbon. The method used will depend on the source of the taste and odour. Adsorption on activated carbon is generally the most effective method for the removal of earthy or mouldy taste and odour. Powdered activated carbon can be dosed directly to the water before coagulation and then subsequently removed by sedimentation. Powdered activated carbon is generally used as a one off treatment. Where regular treatment is required, granular activated carbon (GAC) is the preferred solution and this may be used as a filter medium replacing sand in existing filters or alternatively in a post-filtration adsorption stage. In this arrangement, GAC will need to be periodically removed and regenerated, often by the manufacturer and typically once every 12-24 months. When returned and reinstalled it will require washing and running to waste before being returned to supply. This is to allow any contaminants and impurities to be washed out. In this type of installation it is customary to have a system with several GAC beds so that one can be taken out of service without impacting on overall water quality. In private

water supplies, the usual method is to use a replaceable GAC cartridge located within a standard cartridge filter housing. This cartridge will be replaced at regular intervals.

#### **1.7.4 Nitrate removal**

Nitrate removal is usually achieved by ion-exchange. Water is passed through a column of synthetic resin beads that remove anions including nitrate and exchange them for equivalent amounts of chloride. When the capacity for exchange is exhausted, the resin is regenerated by backwashing with a concentrated solution of sodium chloride. This restores the resin to its initial chloride form. The bed is then rinsed with clean water and returned to service. The waste solution and rinse waters, containing high concentrations of sodium chloride, as well as nitrate, are collected for disposal.

Conventional anion exchange resins have a higher affinity for sulphate than for nitrate. This means that they preferentially remove sulphate and reduce the capacity for nitrate, leading in turn to higher running costs (for regenerant) and greater volumes of waste for disposal. As a result, nitrate selective resins, which give better uptake of nitrate in the presence of sulphate and reduce process costs, are preferred.

Nitrate-selective resins preferentially remove nitrate and also add less chloride to the treated water because of the lower sulphate removal. This is desirable since high chloride concentrations and chloride to bicarbonate ratios are associated with increased corrosion of certain metals. A sodium bicarbonate rinse can be used after regeneration with sodium chloride to convert the resin in the lower part of the bed to the bicarbonate form and reduce the chloride to bicarbonate ratio during the early part of the run.

An ion-exchange plant consists of two or more reactors operated in parallel. Run lengths of up to 24 hours can be achieved before regeneration is necessary. Regeneration consumes up to 2

percent of the volume of treated water and takes about two hours. Performance is affected by the choice of resin, the concentrations of nitrate and sulphate in the raw water, and the volume and concentration of sodium chloride solution used for regeneration. Operation of an ion-exchange plant is normally fully automatic.

Surface waters may require pre-treatment by coagulation to remove organic colour and suspended solids, which would foul the resin.

Nitrate can also be removed by some membrane processes and by biological denitrification. Membrane processes are described in Section 5.8. Resins are available for removal of many anions and cations and have been successfully used at a small scale for removal of colour.

## **1.8 Membrane processes**

The membrane processes of most significance in water treatment are reverse osmosis, ultrafiltration, microfiltration and nanofiltration. These processes have traditionally been applied

to

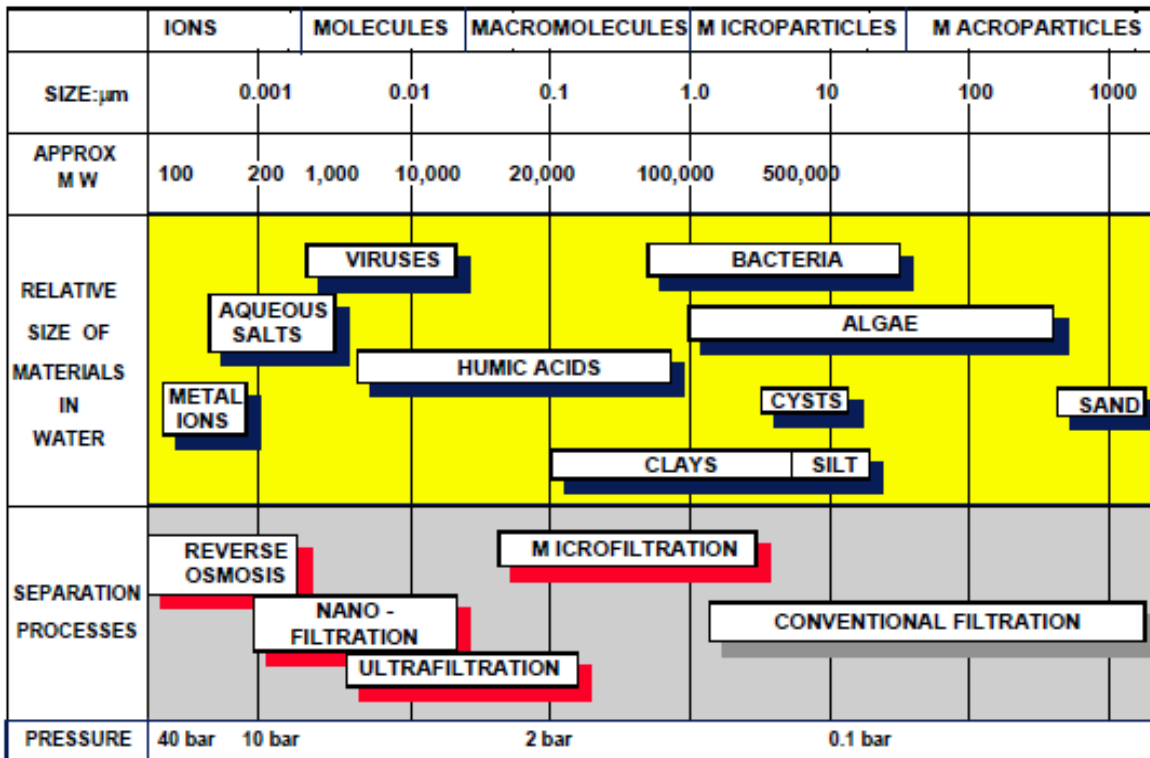

the production of water for industrial or pharmaceutical applications but are now being applied to the treatment of drinking water. Their characteristics are illustrated in Figure 1.

**Figure 1: Characteristics of membrane processes**

If two solutions are separated by a semipermeable membrane, i.e. a membrane that allows the passage of solvent but not of the solute, the solvent will pass from the lower concentration solution to the higher concentration solution. This process is known as osmosis. It is possible, however, to force the flow of solvent in the opposite direction, from the higher to the lower concentration, by increasing the pressure on the higher concentration solution. The required pressure differential is known as the osmotic pressure and the process as reverse osmosis.

Reverse osmosis results in the production of a treated water stream and a relatively concentrated waste stream. Typical operating pressures are in the range 15 to 50 bar depending on the



application. Membrane pore sizes are less than  $0.002\mu\text{m}$ . The most common application of reverse osmosis is desalination of sea water although the use of reverse osmosis for nitrate removal has also been proposed. In the case of private water supplies, reverse osmosis units sold as point of use devices are probably the most common type of membrane process encountered.

Ultrafiltration is similar in principle to reverse osmosis, but the membranes have much larger pore sizes (typically  $0.002$  to  $0.03\mu\text{m}$ ) and operate at lower pressures. Ultrafiltration membranes reject organic molecules of molecular weight above 800 and usually operate at pressures less than 5bar.

Microfiltration is a direct extension of conventional filtration into the sub-micron range. It is capable of sieving out particles greater than  $0.05\mu\text{m}$  and will remove most bacteria and amoeboid cysts. It has been used for water treatment in combination with coagulation or powdered activated carbon (PAC) to remove viruses, bacteria, dissolved organic carbon and to improve permeate flux. Microfiltration membranes have pore sizes typically in the range  $0.01$  to  $12\mu\text{m}$  and do not separate molecules but reject colloidal and suspended material at operating pressures of 1 to 2bar.

Nanofiltration uses a membrane with properties between those of reverse osmosis and ultrafiltration membranes; pore sizes are typically  $0.001$  to  $0.01\mu\text{m}$ . Nanofiltration membranes allow monovalent ions such as sodium or potassium to pass but reject a high proportion of divalent ions such as calcium and magnesium and organic molecules of molecular weight greater than 200. Operating pressures are typically about 5bar. Nanofiltration may be effective for the removal of colour and organic compounds.

Membrane processes can provide adequate removals of pathogenic bacteria, *Cryptosporidium*, *Giardia*, and potentially, human viruses and bacteriophages. However, they should not be relied

upon as the sole means of disinfection as in the case of the types of systems encountered in private supplies there is no simple means to check membrane integrity to warn of potential breakthrough of microorganisms.

## **1.9 Disinfection**

Contamination by sewage or animal faeces is the greatest danger associated with water for drinking. This is because sewage from human or animal sources may contain the causative organisms of many communicable diseases. The use of disinfection to kill or inactivate pathogenic microorganisms is necessary if the raw water contains such organisms.

Surface waters including those feeding springs and shallow wells may contain between a few tens of *E. coli* per 100ml in a source derived from a protected upland catchment to many thousands of *E. coli* per 100ml in a source derived from a lowland river containing treated sewage effluents. Groundwater is generally less microbiologically active, although contamination may occur through geological features like swallow holes, fissures or through poor construction and protection of borehole headworks.

Several disinfection methods are used in water treatment. Disinfection with chlorine is the most widely used method for large water supplies but its application is less common in small supplies.

Ultraviolet irradiation is the most common disinfection method found in private supplies.

Different microorganisms have different susceptibilities to disinfectants, and disinfectants vary in their potency. For a given microorganism, disinfection efficiency is affected especially by disinfectant concentration and contact time, and also by the disinfectant demand of the water, pH and temperature. The product of disinfectant concentration ( $C$  in mg/l, measured at the end of the

contact period) and time (t in minutes) is called Ct (in mg/l.min) and is an expression of exposure to the disinfectant:

$$Ct = C \times t$$

The greater the Ct value, or exposure, the more effective disinfection is. Either concentration or contact time, or both, can be manipulated to obtain a desired Ct value. Values of Ct can be useful for comparing the efficiency of disinfectants; the lower the value of Ct to attain a given kill of microorganisms, the more effective the disinfectant. The Ct value can also be used to rank the relative susceptibility of different microorganisms; the higher the Ct value necessary to achieve a given level of kill the more resistant the microorganism.

In the case of ultraviolet irradiation Ct cannot be calculated in the same way and the exposure is expressed as UV radiation energy density, which is equivalent to (power  $\times$  time) per unit area, expressed in milliwatt seconds per square centimetre (mW.s/cm<sup>2</sup>) or millijoules per square centimeter (mJ/cm<sup>2</sup>).

### **1.9.1 Ultraviolet irradiation**

Ultraviolet (UV) irradiation is the preferred method for disinfection of small supplies with small distribution networks or retention time. Chlorination may be more suitable for larger schemes in which it is necessary to maintain a residual disinfectant during storage and distribution. UV disinfection efficiency is particularly affected by water quality and flow rate. The water to be disinfected must be of good quality and particularly low in colour and turbidity. The usual measure for the suitability of treatment by UV disinfection is UV<sub>254</sub> absorbance, which may be measured with online monitors or sampled and analysed at a laboratory. UV<sub>254</sub> can often vary with levels of colour and organic matter in the water and manufacturers of UV disinfection

equipment will be able to advise on the suitability for particular waters. However, pre-filtration is almost always required prior to UV disinfection, especially if *Cryptosporidium* is likely to be present.

Special lamps are used to generate UV radiation; they are enclosed in a reaction chamber made of stainless steel or, less commonly, plastics. Low pressure mercury lamps, which generate 85% of their energy at a wavelength of 254 nm, are most commonly used. Their wavelength is in the optimum germicidal range of 250 to 265 nm. These lamps are similar in design, construction and operation to fluorescent tubes except that they are constructed of UV transparent quartz instead of phosphor coated glass. The optimum operating temperature of the lamp is around 40°C so the lamp is normally separated from the water by a sleeve to prevent cooling by the water. The intensity of UV radiation emitted decreases with lamp age. Typical lamp life is about 10 to 12 months, after which the output is about 70% of that of a new lamp. Manufacturers will advise on lamp maintenance requirements. It is worth noting that visually a lamp will still appear the same, even when output has decreased, and so the fact that a lamp is emitting light is not necessarily a guarantee that it is delivering the required dose.

The usual UV reactor configuration comprises a quartz sleeved low pressure mercury lamp in direct contact with the water. Water enters the unit and flows along the annular space between the quartz sleeve and the wall of the chamber. Other configurations include lamps separated from the water, for example, those where the lamps are surrounded by bundles of PTFE tubes through which the water flows.

Disinfection will only be effective provided that a sufficient dose of UV is applied. The dose of UV radiation is expressed as an energy flux, in units of mW.s/cm<sup>2</sup> (milliwatt seconds per square centimetre), or more commonly as millijoules per centimeter squared (mJ/cm<sup>2</sup>) which is

the product of the intensity given out by the lamp and the residence time of water in the reactor. The minimum dose required for disinfection depends on several factors, including the susceptibility of microorganisms but is generally taken to be around 40mJ/cm<sup>2</sup>.

It is important, to ensure effective disinfection, that both residence time and UV intensity are adequate. UV intensity will be diminished by ageing of the lamp, fouling of the lamp sleeve by deposits, and absorption of UV radiation by water contaminants such as natural colour. For these reasons lamps need to be changed at the recommended intervals and the quartz sleeve may require periodic cleaning. Some units incorporate a manual wiper for cleaning whilst others incorporate automatic mechanical cleaning.

Colour and turbidity will both affect radiation intensity in the reactor and turbidity may protect microorganisms from the radiation. The water to be treated should be tested for transmissivity or absorbance (UV<sub>254</sub>) by the manufacturer or supplier in order to estimate worst-case transmission values and to adjust contact time accordingly. More advanced units incorporating UV monitors have the facility to automatically adjust the energy input to the UV lamp to achieve the required UV intensity.

Unlike chlorination, UV is effective in inactivating *Cryptosporidium* provided that a sufficient UV dose is applied. However, where *Cryptosporidium* is likely to be present and its removal is required then pre-filtration capable of achieving a turbidity of less than 1NTU is required prior to UV disinfection. Pre-filtration provides an additional barrier to passage of oocysts into the treated water removes particles that shield microorganisms from the UV light and helps to reduce fouling of the UV lamp.

UV irradiation equipment is compact and simple to operate. Maintenance requirements are modest, although specific systematic maintenance is essential. Other advantages include short

contact time and the absence of any known by-products of significance to health. The principal disadvantage is the absence of any residual effect, necessitating careful attention to hygiene in the storage and distribution system.

The build-up of scale on the sleeves of the lamps will eventually reduce their transmittance and they must be cleaned or replaced regularly. Some units have UV intensity monitors and alarms which provide a continuous check on performance and these are strongly recommended. These devices may prevent the flow of water if the required intensity of UV radiation is not achieved, for example when the lamps are warming up or because of scale formation. UV intensity monitors may not be available on smaller units and it is therefore essential that the manufacturer's instructions regarding lamp warmup, cleaning and replacement are followed to ensure optimal performance.

Lamp replacement is usually a simple operation but may involve a significant downtime for reactors with many lamps. This difficulty may be overcome by use of multiple units or by having a treated water storage tank capable of maintaining supply whilst maintenance is carried out.

There are many UV units on the market and care must be taken when selecting a unit for a private water supply. Units must be designed for drinking water treatment,

and where possible, validated units are to be recommended. These will have been tested to ensure that the stated level of disinfection is achieved under normal operating conditions. UV units for ponds and fish tanks etc. are not suitable for use on supplies for human consumption.

### **1.9.2 Chlorine Chemistry**

Chlorine, whether in the form of pure chlorine gas, sodium hypochlorite or calcium hypochlorite, dissolves in water to form hypochlorous acid (HOCl) and hypochlorite ion (OCl<sup>-</sup>). For example, chlorine gas dissolves rapidly in water, initially forming hypochlorous and hydrochloric acids:

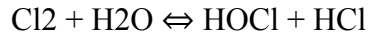

Hypochlorous acid is a weak acid which undergoes partial dissociation to produce a hydrogen ion ( $\text{H}^+$ ) and a hypochlorite ion ( $\text{OCl}^-$ ):



The total concentration of chlorine, hypochlorous acid and hypochlorite ions is referred to as the free available chlorine. If ammonia is present in the raw water, the hypochlorous acid can react to produce chloramines. The total concentration of the chloramines and any organic nitrogen chlorine containing compounds is referred to as the combined available chlorine. Combined available chlorine is a less powerful disinfectant than free available chlorine but gives a more persistent residual.

The formation of combined chlorine is due to a sequence of reactions whereby hydrogen in ammonia is progressively replaced by chlorine as follows:

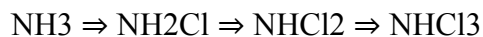

Ammonia Mono Dichloramine Nitrogen

Chloramine trichloride

If a large chlorine dose is applied (relative to ammonia), as is practiced in breakpoint chlorination, then nitrogen is formed.

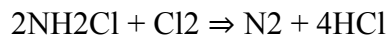

The effectiveness of chlorine for disinfection depends on the form of chlorine, its concentration and the contact time. Hypochlorous acid is a more powerful disinfectant than the hypochlorite ion and chlorination is usually practiced at values of pH favorable to its formation. The World Health Organization recommends that for the effective disinfection of drinking water “the pH should preferably be less than 8.0 and the contact time greater than 30 minutes, resulting in a free

chlorine residual of 0.2 to 0.5mg/l". Figure 13 below shows how the equilibrium between hypochlorous acid and the hypochlorite ion shifts towards the hypochlorite ion as pH increases.

Chlorination processes need to be carefully controlled in order to minimise the formation of taste and odour forming compounds. There may also be a need to control the formation of disinfection by-products including THMs. Therefore, for small supplies, consideration should be given to using alternatives to chlorination, such as UV.

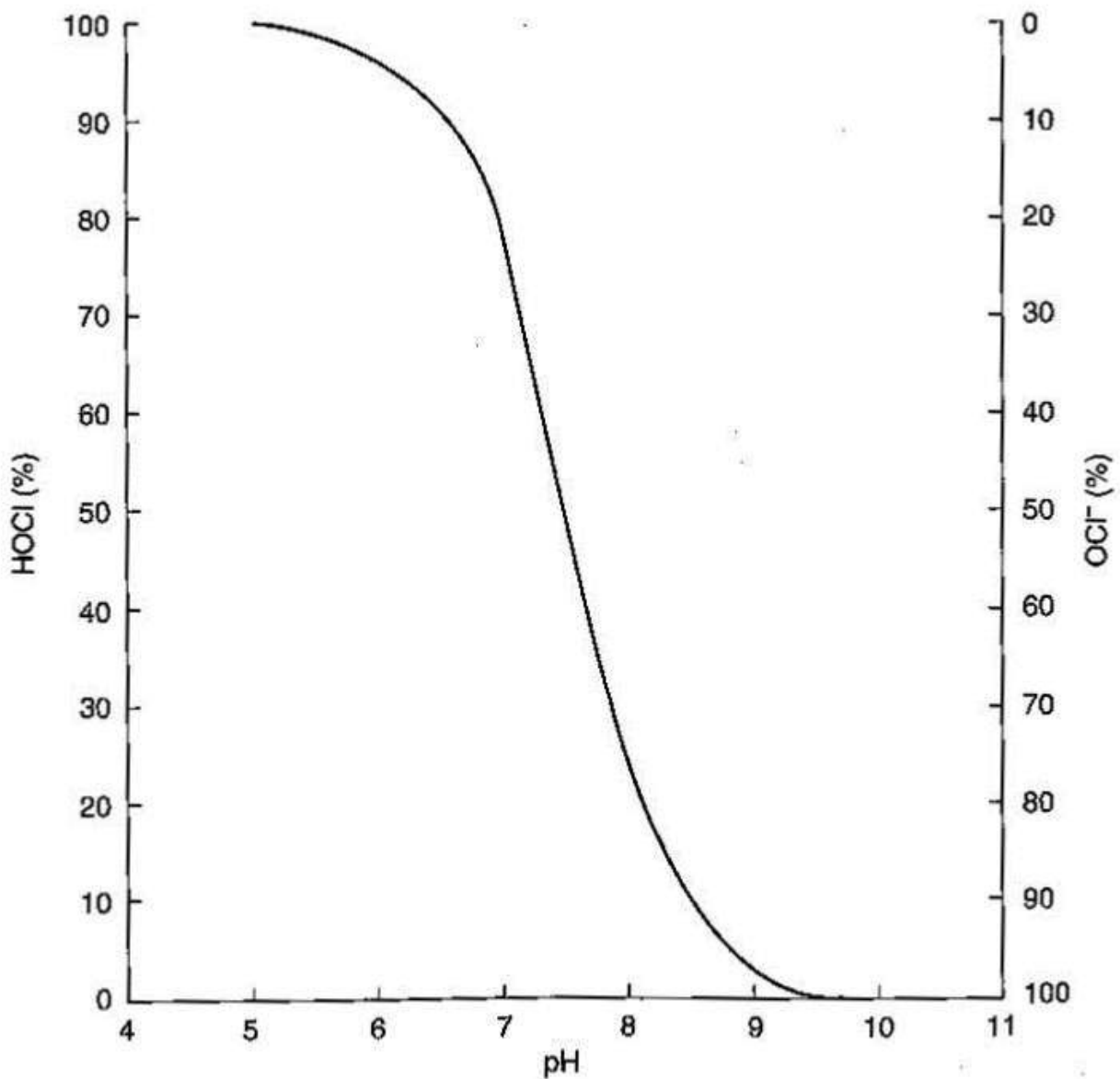



## **Figure 2: hypochlorous acid and hypochlorite ion equilibrium**

### **1.9.3 Sources of chlorine**

Chlorination can be achieved by using liquefied chlorine gas, sodium hypochlorite solution or calcium hypochlorite granules. Chlorine gas is very reactive and highly toxic and must be carefully stored and handled. It is used for treatment of large public supplies but the inherent danger of using chlorine gas has resulted in an increased use of sodium hypochlorite or the electrolysis of brine (electro-chlorination) as alternative sources of chlorine.

The use of chlorine gas for treatment of small water supplies is not recommended. Gas chlorination is generally not appropriate for supplies of less than 10m<sup>3</sup>/d or where the available head is less than about 4.0m. Leaks of chlorine gas are very dangerous. A separate area is necessary for storage of chlorine gas and an alarm system to detect leakage of chlorine must be installed. It is common practice to install alarm systems to indicate failure of the chlorine injector system or carrier water flow. Liquefied chlorine gas is supplied in pressurised containers. The gas is withdrawn from the cylinder and is dosed into water by a chlorinator, which both controls and measures the gas flow rate.

Sodium hypochlorite solution (14 to 15% by mass (m/m) available chlorine) can be delivered to site in drums. No more than one month's supply should be delivered at one time, as its

decomposition (particularly on exposure to light) results in a loss of available chlorine and an increase in concentration of chlorate, relative to chlorine.

Alternatively, sodium hypochlorite solution (0.5 to 1.0% mass per volume (m/V) available chlorine) can be generated on site by the electrolysis of brine (sodium chloride solution). A typical electro-chlorination system consists of a water softener, a salt saturator, a voltage rectifier, an electrolysis cell and a storage tank containing up to three day's supply of hypochlorite solution. Hydrogen, which is produced during electrolysis, must be vented safely. These systems are compact and eliminate the need to store and handle the toxic and corrosive chlorination chemicals.

There is a wide choice of equipment available for dosing sodium hypochlorite solution. Simple gravity fed systems in which sodium hypochlorite solution is dripped at a constant rate into a tank of water have been used successfully and have proven reliable provided that the rate of flow into supply and the chlorine demand of the water are constant. Where the flow is more variable, water powered hypochlorinators that adjust the flow of sodium hypochlorite proportionately to the flow of water may be suitable. Electric dosing pumps can operate under flow proportional or chlorine residual control and thus maintain a consistent chlorine residual under conditions of variable flow or chlorine demand.

Calcium hypochlorite can be supplied in powdered, granular or tablet form (65 to 70% m/m available chlorine). Calcium hypochlorite is stable when dry and several month's supply can be stored. It will however react with moisture in the air to form chlorine gas. Calcium hypochlorite dosing equipment is relatively simple. Most allow calcium hypochlorite to dissolve in a known volume of make-up water, which is then mixed with the main supply. Tablets are most commonly used, as their rate of dissolution is predictable. Control of dosage (proportional to the

rate of dissolution) is often limited to changing the depth of immersion of the tablets in the make-up water or to changing the proportion of the make-up water to total flow.

#### **1.9.4 Methods of chlorination**

Several regimes of chlorination can be used, including marginal (simple) chlorination, breakpoint chlorination, superchlorination/dechlorination and chloramination. On small supplies, it is probable that only marginal chlorination would be used in most cases. Marginal chlorination involves the dosing of chlorine to produce a suitable residual free available chlorine concentration.

Breakpoint chlorination can and is used for removal of ammonia. Sufficient chlorine is added to exceed the demand for chloramine production and to ensure a free available chlorine residual. The chlorine dose must be carefully controlled to avoid forming dichloramine and nitrogen trichloride which can cause taste and odour problems. Breakpoint chlorination requires a dose of around 10 mg/l chlorine dosed per mg/l ammonia removed. The actual dose depends on water quality and has to be determined for each water.

The resultant free available chlorine residual should remain in the range 0.2 to 0.5mg/l. It is recommended that the contact time should be at least 30 minutes. The design of the contact system is very important. Applied chlorine must be mixed rapidly with the water and then passed through a contact tank, ideally with baffles or a serpentine arrangement to prevent short circuiting or retention in dead zones.

#### **1.9.5 Control of chlorination**

Chlorine residual control is the most common method of control where chlorine is dosed continuously into the water. If the quality of the water and hence the chlorine demand varies appreciably, it is necessary to use a control system to maintain a constant chlorine residual. A

sample of chlorinated water is withdrawn downstream of the chlorination system and the chlorine residual in the treated water is monitored continuously. The signal from the chlorine analyser system is used to adjust the chlorine dose thus maintaining the required residual chlorine concentration. Where water quality is consistent, constant rate control or flow proportional control may be appropriate. In the former, a constant dose of chlorine is applied and in the latter a chlorine dose proportional to the flow of water is applied automatically under control of a signal from the flow sensor. There is no standard for chlorine in the regulations, but excess levels give rise to customer complaints of taste and odour.

### **1.10 Corrosion control**

Corrosion is the partial dissolution of the materials constituting the treatment and supply systems, tanks, pipes, valves, and pumps. It may lead to structural failure, leaks, loss of capacity, and deterioration of chemical and microbiological water quality. The internal corrosion of pipes and fittings can have a direct impact on the concentration of some water constituents, including lead, copper and nickel. Corrosion control is therefore an important aspect of the management of a water supply system.

Corrosion control involves many parameters, including the concentrations of calcium, bicarbonate, carbonate, and dissolved oxygen, as well as pH. The detailed requirements differ depending on water quality and for each distribution system material. The pH controls the solubility and rate of reaction of most of the metal species involved in corrosion reactions. It is particularly important in relation to the formation of a protective film at the metal surface. For particular metals, alkalinity (carbonate and bicarbonate) and calcium (hardness) also affect corrosion rates.

#### **1.10.1 Concrete and cement**

Concrete is a composite material consisting of a cement binder in which an inert aggregate is embedded. Cement is primarily a mixture of calcium silicates and aluminates together with some free lime. Cement mortar, in which the aggregate is fine sand, is used as a protective lining in iron and steel water pipes. In asbestos-cement pipe, the aggregate is asbestos fibres. It should be noted that research has indicated that the use of asbestos in cements in water mains does not pose a health risk. Cement is subject to deterioration on prolonged exposure to aggressive water, due either to the dissolution of lime and other soluble compounds or to chemical attack by aggressive ions such as chloride or sulphate and this may result in structural failure. Aggressiveness to cement is related to the “Aggressivity Index”, which has been used specifically to assess the potential for the dissolution of concrete. A pH of 8.5 or higher may be necessary to control cement corrosion.

### **1.10.2 Copper**

Copper tubing may be subject to general corrosion, impingement attack and pitting corrosion. General corrosion is most often associated with soft, acid waters; waters with pH below 6.5 and hardness of less than 60 mg/l CaCO<sub>3</sub> are very aggressive to copper. Impingement attack is the result of excessive flow velocities and is aggravated in soft water at high temperature and low pH. The pitting of copper is commonly associated with hard groundwater having a carbon dioxide concentration above 5mg/l and high dissolved oxygen. Surface waters with organic colour may also be associated with pitting corrosion. A high proportion of general and pitting corrosion problems are associated with new pipe in which a protective oxide layer has not yet formed.

### **1.10.3 Lead**

Lead corrosion (plumbosolvency) is of particular concern. Lead piping is still common in old houses, and lead solders have been used widely for jointing copper tube. The solubility of lead is governed by the formation of insoluble lead carbonates. The solubility of lead increases markedly as the pH is reduced below 8 because of the substantial decrease in the equilibrium carbonate concentration. Thus, plumbosolvency tends to be at a maximum in waters with a low pH and low alkalinity, and a useful interim control procedure pending pipe replacement is to maintain pH in the range 8.0 to 8.5 and possibly to dose orthophosphate.

#### **1.10.4 Nickel**

Concentrations of nickel up to around 1 mg/l may arise due to the leaching of nickel from new nickel-chromium plated taps and from stainless steel pipes and fittings. Nickel leaching reduces over time. Increase of pH to control corrosion of other materials should also help to reduce leaching of nickel.

#### **1.10.5 Water treatment for corrosion control**

To control corrosion in water distribution networks the methods most commonly applied are adjusting pH, increasing the alkalinity and/or hardness, or adding corrosion inhibitors such as sodium polyphosphates or silicates and orthophosphate. The quality and maximum dose to be used should be in line with appropriate national specifications for such water treatment chemicals. Although pH adjustment is an important approach its possible impact on other aspects of water supply technology, including disinfection, must always be taken into account.

Treatment to reduce plumbosolvency usually involves pH adjustment. When the water is very soft (less than 50mg/l CaCO<sub>3</sub>), the optimum pH is about 8.0 to 8.5. Alternatively, dosing with orthophosphoric acid or sodium orthophosphate might be more effective particularly when plumbosolvency occurs in nonacidic waters. Wherever practicable, lead pipework should be

replaced. Grants for pipe replacement may be available from the local authority and some water companies offer a lead pipe replacement service.

## **2.0 Selection of water treatment processes**

Selecting the appropriate treatment process is a critical step in providing safe, reliable, good quality drinking water at a cost-effective price. There is a need for raw water quality data that cover an extended period sufficient to show seasonal and extreme events to make a sound decision on appropriate treatment processes. Before any process is finally selected, it is important to carry out treatability testing on the actual source water. All waters have subtle differences, and these can have a significant effect on process selection and performance. Water treatment process selection is a complex task. Circumstances are likely to be different for each water utility and perhaps may be different for each source used by one utility. Selection of one or more water treatment processes to be used at a given location is influenced by the necessity to meet regulatory quality goals, the desire of the utility and its customers to meet other water quality goals (such as aesthetics), and the need to provide water service at the lowest reasonable cost.

Water treatment operations must be designed to handle the extremes in raw water quality variation to provide an acceptable product water at all times. As illustrated in Table 2.1, a summary of more common drinking water treatment processes, there are many treatment options available to the designer to achieve the desired water quality results.

Table 2.1: Most common drinking water treatment processes (Fulton, 2005)

Water quality parameter	Process components
Turbidity-particulate reduction	<p>Filtration</p> <ul style="list-style-type: none"> <li>• Rapid sand-conventional</li> </ul> <p>Coagulation, flocculation</p> <ul style="list-style-type: none"> <li>• Clarification</li> </ul> <p>Plain settling, Plate settlers</p> <p>Solids contact</p> <p>Dissolved air flotation</p> <p>Filtration</p> <ul style="list-style-type: none"> <li>• Rapid sand-direct mode</li> </ul> <p>Coagulation, flocculation</p> <p>Filtration, Slow sand filtration</p> <ul style="list-style-type: none"> <li>• Diatomaceous earth filtration</li> <li>• Membrane filtration</li> </ul> <p>Ultrafiltration, Nanofiltration</p> <p>Reverse osmosis</p>
Bacteria, viruses, cyst removal	<p>Partial reduction-filtration (above)</p> <p>Inactivation-disinfection</p> <ul style="list-style-type: none"> <li>• Chlorine</li> <li>• Chloramine</li> <li>• Chlorine dioxide</li> <li>• Ozone</li> <li>• UV</li> </ul>



Color	<p>Coagulation/Rapid sand filtration</p> <p>Adsorption</p> <ul style="list-style-type: none"> <li>• Granular activated carbon (GAC) media</li> <li>• Powdered activated carbon (PAC) addition</li> <li>• Synthetic resins (Ion exchange)</li> </ul> <p>Oxidation</p> <ul style="list-style-type: none"> <li>• Ozone</li> <li>• Chlorine</li> <li>• Chlorine dioxide</li> <li>• Potassium permanganate</li> </ul> <p>Nanofiltration</p>
Taste and color control	<p>Oxidation</p> <ul style="list-style-type: none"> <li>• Ozone</li> <li>• Chlorine</li> <li>• Chlorine dioxide</li> <li>• Potassium permanganate</li> <li>• Biologically activated carbon (BAC) adsorption</li> </ul>
Volatile organic reduction	<p>Air stripping</p> <ul style="list-style-type: none"> <li>• GAC adsorption</li> <li>• Combination of the above</li> </ul>
Disinfection by-product control	Precursor reduction

	<ul style="list-style-type: none"> <li>• Enhanced coagulation</li> <li>• GAC adsorption</li> <li>• BAC media-pre ozonation</li> <li>• Nanofiltration</li> </ul> <p>By-product removal</p> <ul style="list-style-type: none"> <li>• GAC adsorption</li> <li>• Air stripping (partial)</li> </ul>
Iron, manganese reduction/sequestering	<p>Filtration of precipitators formed by peroxidation</p> <ul style="list-style-type: none"> <li>• Sand and/or anthracite media</li> <li>• Green sand media</li> <li>• Proprietary media</li> </ul> <p>Polyphosphate sequestering agent</p>
Hardness reduction	<p>Lime softening</p> <ul style="list-style-type: none"> <li>• Ion exchange</li> <li>• Nanofiltration</li> </ul>
Inorganic, organic chemical reduction	<p>Ion exchange</p> <p>BAC media</p> <p>Adsorption</p> <p>Reverse osmosis</p>

Corrosion control	Posttreatment <ul style="list-style-type: none"><li>• pH adjustment</li><li>• Inhibitors</li></ul>
-------------------	--

## References

C. N. Sawyer, P. L. U.S. Environmental Protection Agency, *Enhanced Coagulation and Enhanced Precipitative Softening Guidance Manual*, EPA/815/R-99/012, National Service Center for Environmental Publications, Cincinnati, OH, 1999.

G. S. Logsdon, et al. *J. Amer. Water Works Assoc.* **77**(2), 61 (1985).

M. L. Davis and D. A. Cornwell, *Introduction to Environmental Engineering*, PWS Publishers, Boston, MA, 1985.

McCarty, and G. E. Parkin, *Chemistry for Environmental Engineering*, 4th ed., McGraw-Hill, New York, NY, 1994.

Michael Muntisov “ Guide to Selection of Water Treatment Processes” April 2005  
<https://doi.org/10.1002/047147844X.mw186>

R. A. Corbitt, *Standard Handbook of Environmental Engineering*, McGraw-Hill, New York, NY, 1990.

Ronald Droste “ Theory And Practice Of Water And Wastewater Treatment  
ISBN 10: [0471124443](#) ISBN 13: [9780471124443](#)

## MODULE 4 WASTEWATER MANAGEMENT

Wastewater or sewage is the by-product of many uses of water. There are the household uses such as showering, dishwashing, laundry and, of course, flushing the toilet. Additionally, companies use water for many purposes including processes, products, and cleaning or rinsing of parts. After the water has been used, it enters the wastewater stream, and it flows to the wastewater treatment plant.

The goal of wastewater management is to clean and protect water. This means that water must be clean enough so that it can be used by people for drinking and washing, and by industry for commercial purposes. It also must be clean enough to release into oceans, lakes, and rivers after it has been used.

### 4.1 Wastewater Production,

Wastewater is produced at three main sources as shown on Fig 1 below.

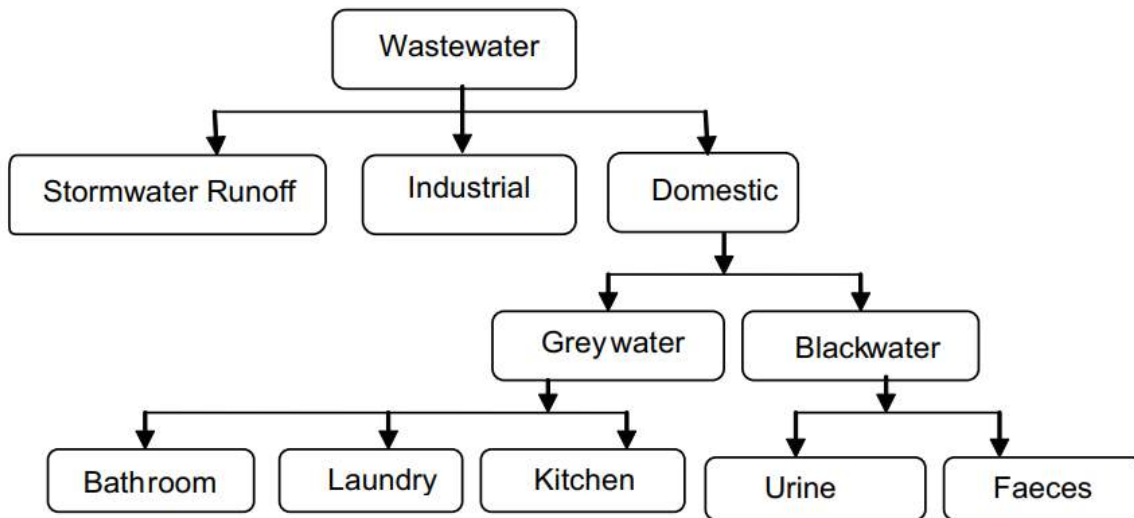

**Fig. 1. Types of Wastewater**

### 4.2 Sewer Networks,

Sewerage system, network of pipes, pumps, and force mains for the collection of wastewater, or sewage, from a community. Modern sewerage systems fall under two categories: domestic and industrial sewers and storm sewers. Sometimes a combined system provides only one network of pipes, mains, and outfall sewers for all types of sewage and runoff. The preferred system, however, provides one network of sewers for domestic and industrial waste, which is generally treated before discharge, and a separate network for storm runoff, which may be diverted to

temporary detention basins or piped directly to a point of disposal in a stream or river. See wastewater treatment.

### **4.3 Waste Water Treatment,**

Sewage treatment involves three stages: primary treatment, secondary treatment, and tertiary treatment. Primary treatment physically separates solids and liquids. The wastewater passes through a grating that strains out large particles. The remaining water is left to stand in a tank, where smaller sediments (particles of sand, clay, and other materials) settle to the bottom. These sediments are called sludge. At this point, the liquid part of the wastewater still contains many pollutants and is not safe for exposure to humans or the environment.

In the second step, called secondary treatment, the liquid part of the wastewater passes through a trickling filter or an aeration tank. A trickling filter is a set of pipes with small holes in it that dribbles water over a bed of stones or corrugated plastic. Bacteria in the stones or plastic absorb pollutants from the water and break them down into substances that are not harmful. An aeration tank is a tank that contains bacteria that break down pollutants. The liquid part of the wastewater from primary treatment is pumped into the tank and mixed with the bacteria. Air is bubbled through the tank to help the bacteria grow. As bacteria accumulate, they settle to the bottom of the tank and form sludge. The sludge is removed from the bottom of the tank and buried in landfills

After secondary treatment, the water is generally free from the majority of pathogens and heavy metals. It still contains high concentrations of nitrate and phosphate, minerals that can overstimulate the growth of algae and plants in natural waters, which can ultimately cause them and the surrounding organisms to die. Tertiary treatment removes these nutrients from the wastewater. One method of tertiary treatment involves using biological, chemical, and physical processes to remove these nutrients. Another method is to pass the water through a wetland or lagoon (shallow body of water cut off from a larger body

#### **4.3.1 Physical unit operations**

Unit operations involve a physical change or chemical transformation such as separation, crystallization, evaporation, filtration, polymerization, isomerization, and other reactions. For example, in milk processing, the following unit operations are involved: homogenization, pasteurization, and packaging.

#### **4.3 2 Screening**

Wastewater Screening is the first unit operation in all wastewater treatment plants. Screen is the device used to retain solids found in the influent wastewater to the treatment plant. The main purpose of screening is to remove solid materials that could: Cause damage to other process equipment.

### **4.3.2 Comminution**

Comminution is the reduction of solid materials from one average particle size to a smaller average particle size, by crushing, grinding, cutting, vibrating, or other processes. In geology, it occurs naturally during faulting in the upper part of the Earth's crust. In industry, it is an important unit operation in mineral processing, ceramics, electronics, and other fields, accomplished with many types of mill. In dentistry, it is the result of mastication of food. In general medicine, it is one of the most traumatic forms of bone fracture.

### **4.3.3 Flow equalization**

Flow equalization is method used to overcome the operational problems and flow rate variations to improve the performance of downstream processes and to reduce the size & cost of downstream treatment facilities. To prevent flow rate, temperature, and contaminant concentrations from varying widely, flow equalization is often used. Benefits - Advantages of 1) Flow Equalization Tank 2) Reduction of peaking requirements 3) Reduction of process overloads at existing plants under some conditions 4) Protection against toxic upsets 5) Potential reduction of operational problems 6) Provides increasing benefits with increasing plant complexity 7) Placement of equalization following primary treatment minimizes operation and maintenance, and minimizes requirements for solids removal, aeration, and odor control equipment

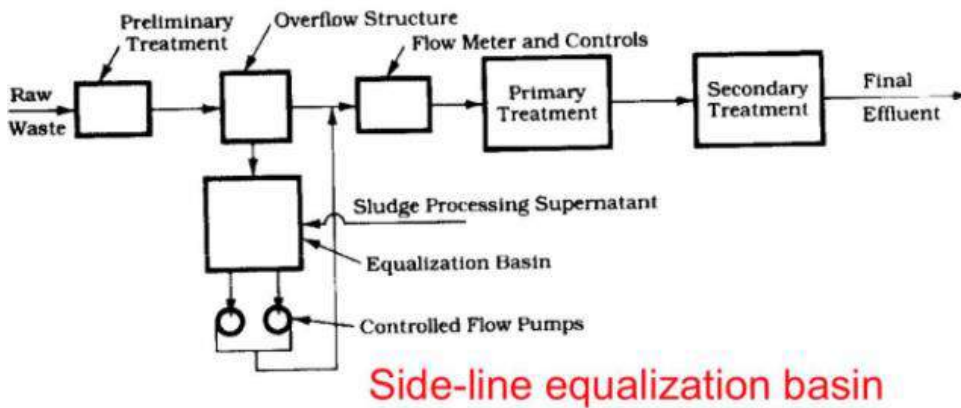
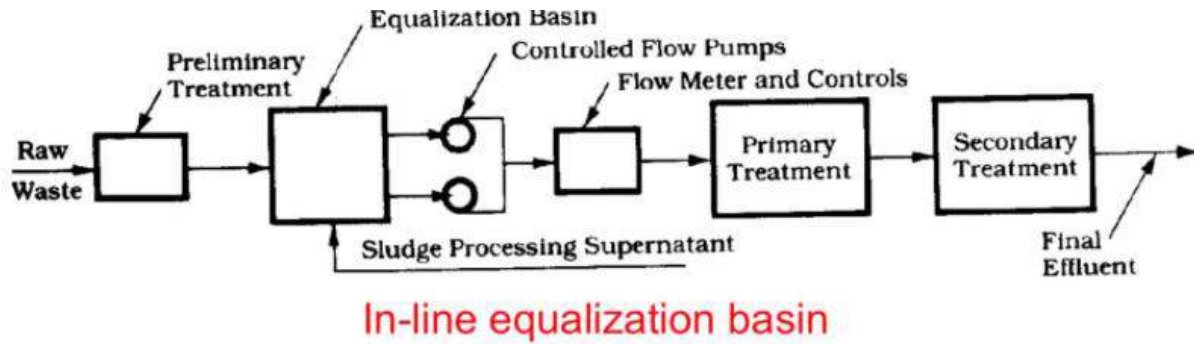

#### 4.3.4 Sedimentation

Sedimentation is a process by which heavier impurities present in liquid normally water settle down at the bottom of the container containing the mixture. The process takes some amount of time.

#### • 4.3.5 Flotation

The treatment of aqueous or oily effluents is one of the most serious environmental issues faced by the minerals and metallurgy industries. Main pollutants are residual reagents, powders, chemicals, metal ions, oils, organic and some may be valuable (Au, Pt, Ag). The use of flotation is showing a great potential due to the high throughput of modern equipment, low sludge generation and the high efficiency of the separation schemes already available

#### **Granular-medium filtration**

Granular media filtration (GMF) is a process for removing suspended or colloidal particles; for example removing suspended solids remaining after sedimentation clarification. It reduces turbidity and improves clarity by removing various sized particles, from coarse sediment down to 10.0  $\mu\text{m}$

#### **Chemical unit operations**

There are several distinct chemical unit processes, including chemical coagulation, chemical precipitation, chemical oxidation, and advanced oxidation, ion exchange, and chemical neutralization and stabilization, which can be applied to wastewater during cleaning. Chemicals are used during wastewater treatment in an array of processes to expedite disinfection. These chemical processes, which induce chemical reactions, are called chemical unit processes and are used alongside biological and physical cleaning processes to achieve various water standards. Specialized chemicals such as chlorine, hydrogen peroxide, sodium chlorite, and sodium hypochlorite (bleach) act as agents that disinfect, sanitize, and assist in the purification of wastewater at treatment facilities.

### **Chemical precipitation**

Chemical precipitation, formation of a separable solid substance from a solution, either by converting the substance into an insoluble form or by changing the composition of the solvent to diminish the solubility of the substance in it.

### **Adsorption**

Adsorption is a commonly used method for industrial wastewater treatment because of its low-cost, easy operation and high efficiency. In this work, chitosan was crosslinked and functionalized with a low-cost phosphonium salt, tetrakis (hydroxymethyl)phosphonium sulfate (THPS), to enhance its adsorption capacity for Cr (VI).

#### **• Disinfection**

The disinfection of potable water and wastewater provides a degree of protection from contact with pathogenic organisms including those causing cholera, polio, typhoid, hepatitis and a number of other bacterial, viral and parasitic diseases. Disinfection is a process where a significant percentage of pathogenic organisms are killed or controlled.

#### **• Dichlorination Wastewater Management 383**

Dichlorination is a process by which some or most of the chlorine is removed as per the required use. Dichlorination is carried out in many instances, but the most complicated one of all is wastewater effluent dichlorination because of the need to reduce the amount of total chlorine residual below 0.01 mg Cl<sub>2</sub>/L in the effluent to reduce toxicity.

#### **• Other chemical applications**

Other chemicals used in other applications in this process are alum and ferric sulfate and ferric chloride, aluminum sulfate, among others. A second use of chemicals in wastewater treatment, is to adjust the pH level. Almost every industrial manufacturing company and wastewater treatment operation deals with pH Adjustment on some level.



## **Biological unit operations**

Biological Unit Processes □ Biological unit processes are those in which removal of contaminants are brought about by biological activity □ In biological treatment of waste water, the objectives are to coagulate and remove the non settleable colloidal solids and to stabilise the organic matter. □ The waste water is generally from three sources (i) domestic waste water (ii) agricultural return waste water (iii) industrial waste water □ For domestic waste water, the objectives is to remove various nutrients, specifically nitrogen and phosphorous, which are other wise capable of stimulating growth of aquatic plants

### **Activated sludge process**

The activated sludge is a process with high concentration of microorganisms, basically bacteria, protozoa and fungi, which are present as loose clumped mass of fine particles that are kept in suspension by stirring, with the aim of removing organic matter from wastewater.

### **Aerated lagoon**

An **aerated lagoon** (or aerated pond) is a simple wastewater treatment system consisting of a pond with artificial aeration to promote the biological oxidation of wastewaters. There are many other aerobic biological processes for treatment of wastewaters, for example activated sludge, trickling filters, rotating biological contactors and biofilters.

### **Trickling filters**

A trickling filter is a type of wastewater treatment system. It consists of a fixed bed of rocks, coke, gravel, slag, polyurethane foam, sphagnum peat moss, ceramic, or plastic media over which sewage or other wastewater flows downward and causes a layer of microbial slime (biofilm) to grow, covering the bed of media

### **• Rotating biological contactors**

The rotating biological contactor (RBC) is a fixed film biological secondary treatment device. The basic process is similar to that occurring in the trickling filter. In operation, a media, consisting of a series of circular disks mounted side by side on a common shaft is rotated through the wastewater flow. The purpose of an RBC is to remove soluble food from the water. Soluble food is often referred to as soluble BOD. For this reason, the RBC must be preceded by primary settling.

### **Pond stabilization**

Waste stabilization ponds (WSPs or stabilization ponds or waste stabilization lagoons) are ponds designed and built for wastewater treatment to reduce the organic content and remove pathogens from wastewater. They are man-made depressions confined by earthen structures. Wastewater or

"influent" enters on one side of the waste stabilization pond and exits on the other side as "effluent"

### **Anaerobic digestion**

Anaerobic digestion is a sequence of processes by which microorganisms break down biodegradable material in the absence of oxygen. The process is used for industrial or domestic purposes to manage waste or to produce fuels.

Urban Drainage,

The purpose of Urban drainage is To maintain such an environment that not affect the public health in general. The creation of such conditions of living which will not result into serious outbreak of epidemic diseases. Objectives of Urban Drainage Systems

The four major objectives of drainage and sewer systems are:

Public health and safety

Environmental protection

Sustainable development

Occupational health and safety

Drain and Sewer systems are provided in order to prevent spread of diseases by:

Preventing contact with faecal and other waterborne waste,

Protecting drinking water sources from contamination by waterborne waste and

Carrying runoff and surface water away while minimizing hazards to the public. Purpose of Urban Drainage Systems

The purpose of Urban drainage is:

To maintain such an environment that not affect the public health in general.

The creation of such conditions of living which will not result into serious outbreak of epidemic diseases.

It is the control of environmental pollution, improve environmental quality to enable healthy ecosystem and comfortable habitation to human.

It is a preventive measure for the preservation of health of the community in general and individual in particular.

Sewer systems should be designed, constructed, operated, maintained and rehabilitated in such a way that they are sustainable and can be operated with the minimum use of energy.

### **Urban runoff**

When rain falls on natural lands such as forests and meadows, some of it soaks into the soil and then slowly makes its way to rivers, lakes, and oceans. In cities, much of the land is paved with cement and asphalt, and water is unable to sink into the ground. Instead, it quickly moves to storm drains and then into natural waterways. This great volume of water causes much erosion (wearing away of the land) and sedimentation. In addition, as the rainwater runs over paved surfaces, it gathers oil and grease from cars, fertilizers and pesticides from gardening, pathogens from animal wastes, road salts, and heavy metals. These are dumped directly into natural waters with urban wastewater. Runoff from urban areas is the largest source of pollution in estuaries (the wide part of a river where it nears the sea) and the third largest source of pollution in lakes.

Controlling urban runoff is extremely difficult because its sources are hard to identify. The Environmental Protection Agency works to influence developers to take into account urban runoff when planning new buildings. Some ideas to minimize runoff include adding vegetation and drainage areas to new construction sites. Some cities have instituted sewer-stenciling programs that remind people that rainwater flows directly into natural waters. Gas stations have also been targeted as businesses that can help control car oils and grease. Schools have also developed programs to teach students about urban runoff and non-point source wastewater.

### **Surface Water Pollution Loading, Storm Water Sewer and Pipe Flow Networks**

#### **Sediment Transport,**

Sediment transport is the movement of solid particles (sediment), typically due to a combination of gravity acting on the sediment, and/or the movement of the fluid in which the sediment is entrained

The simplest definition of sediment transport is the transport of granular particles by fluids. The main agents by which sedimentary materials are moved include gravity (gravity transport), river and stream flow, ice, wind, and estuarine and ocean currents. Running water and wind are the most widespread transporting agents. In both cases, three mechanisms operate, although the particle size of the transported material is very different, owing to the differences in density and viscosity of air and water. The three processes are rolling or traction, in which the particle moves along a sedimentary bed but is too heavy to be lifted from it; saltation; and suspension, in which particles remain permanently above the bed, sustained there by the turbulent flow of the air or water (U.S. Army Corps of Engineers, 2003).

#### **Water Quality Impacts.**

All household wastewater from pipes connected to urban homes, businesses and schools goes to a wastewater treatment plant. (A small percentage of people have composting toilets and alternative greywater systems.) Once we have used water, it must be treated before being returned to the environment. Like water treatment for supply, this process has a cost, and the more water we use in our houses, schools and businesses, the more water there is to treat.

In rural areas, household wastewater is treated in wastewater treatment systems and septic tanks and disposal fields in the soil.

Wastewater must be treated to reduce bacteria, nutrients such as phosphate in faeces and detergents and nitrogen in urine. Nutrients increase the growth of plants in waterways, and this can lead to eutrophication

## **MODULE 5: WETLANDS AND ESTUARINE**

### 5.1 What is Wetland?

Wetlands are defined directly or implicitly in a variety of ways. Several factors, including personal perspective, position in the landscape, and wetland diversity and function, contribute to the tractable nature of the definition. Each individual or group brings to the definition its own perspective based upon cumulative experience and personal needs. For example, the lay person asked to define wetlands may envision a deep-water marsh teeming with ducks, or alternatively a dark swamp. To an engineer a wetland may be a place that will require a specialized construction design to accommodate poorly drained soils. The scientist likely has a functional perspective, defining a wetland as a place where anaerobic processes occur, and plants are adapted specially for living in saturated or inundated conditions. Finally, those charged with regulating wetland use are likely to have a structural perspective, defining wetlands by characteristic soil, hydrology, and plants so as to facilitate permit decision making.

Defining wetlands is further complicated by their position in the landscape. Wetlands are transitional habitats in the sense that they are neither terrestrial nor aquatic, but exhibit characteristics of both. Their boundaries are part of a continuum of physical and functional characters and may expand or contract over time depending upon factors such as average annual precipitation, evapotranspiration, and modifications to the watershed. The transitional nature of wetland characteristics and the shifting of wetland boundaries renders precise identification of wetland boundaries difficult if not impossible. The diversity of wetland types also contributes to the tractable nature of the definition. Wetlands include such familiar habitats as marsh and swamp, as well as less familiar seasonal wetlands such as vernal pools and intermittent streams. They may be tidal or nontidal, saline or fresh, lotic or lentic, permanent or impermanent. Vegetation may consist of herbaceous or woody species, or there may be no vegetation.

Wetlands also defy a unifying functional definition. Each wetland is unique with respect to its size, shape, hydrology, soils, vegetation, and its position in the landscape. As such, wetlands exhibit a wide range of functional attributes, including provision of aquatic and wildlife habitat, retention of sediments and toxicants, flood attenuation, nutrient metabolism, groundwater recharge, and production export. Individual wetlands may exhibit some of these attributes, all of these attributes, or in rare instances, none of these attributes. Moreover, individual wetlands of similar attributes are likely to provide functions to differing degrees. Despite the difficulty in singularly defining wetlands, several formal definitions have been proposed. The earliest definition was for managers and scientists, particularly those concerned with waterfowl and wildlife. Largely a structural definition, it uses language understandable to the lay person.

Despite the difficulty in singularly defining wetlands, several formal definitions have been proposed. The earliest definition was for managers and scientists, particularly those concerned

with waterfowl and wildlife. Largely a structural definition, it uses language understandable to the lay person.

The term wetland refers to lowlands covered with shallow and sometimes temporary or intermittent waters. They are referred to by such names as marshes, swamps, bogs, wet meadows, potholes, sloughs, and river-overflow lands. Shallow lakes and ponds, usually with emergent vegetation as a conspicuous feature, are included in the definition, but the permanent waters of streams, reservoirs, and deep lakes are not included. Neither are water areas that are so temporary as to have little or no effect on the development of moist-soil vegetation. The definition established two parameters essential for a habitat to be a wetland: the presence of surface water and the development of moist-soil vegetation. At a workshop of the Canadian National Wetlands Working Group, 23 years later, a definition evolved that recognized a third parameter, hydric soils, and which noted the functional attributes of wetlands. Furthermore, it expanded the previous definition of wetland to include not only those habitats with surface water but also those having saturated soils.

Wetland is defined as land having the water table at, near, or above the land surface or which is saturated for a long enough period to promote wetland or aquatic processes as indicated by hydric soils, hydrophilic vegetation, and various kinds of biological activity which are adapted to the wet environment. Wetlands are lands transitional between terrestrial and aquatic systems where the water table is usually at or near the surface or the land is covered by shallow water. For purposes of this classification wetlands must have one or more of the following three attributes:

- 1) At least periodically, the land supports predominantly hydrophytes.
- 2) The substrate is predominantly undrained hydric soils; and
- 3) The substrate is nonsoil and is saturated with water or covered by shallow water at some time during the growing season each year.

The term “wetlands” means those areas that are inundated or saturated by surface or ground water at a frequency and duration sufficient to support, and that under normal circumstances do support, a prevalence of vegetation typically adapted for life in saturated soil conditions. Wetlands generally include swamps, marshes, bogs, and similar areas.



Figure 1: Sample Wetland

## 5.2 Wetland Types and Classifications

Wetlands have different characteristics. The most common feature of all wetlands is that the water table (the groundwater level) is very near to the soil surface or shallow water covers the surface for at least part of the year. The main characteristics of a wetland are determined by the combination of the salinity of the water in the wetland, the soil type and the plants and animals living in the wetland. Because of the high variability of the conditions, and because of the different needs for distinguishing among different types of wetlands, so far, there is no single wetlands classification system that would account for the manifold aspects of this specific ecosystem type. More details about the two major types of classification of wetlands are presented in this section.

1. Dependent mostly on a combination of the above conditions, the "traditional terminology" distinguishes between two major wetland types – mineral and organic (*Encyclopædia Britannica*; FORESTED WETLANDS: Functions, Benefits, and the Use of Best Management Practices), such as marsh, swamp, fen, and bog.

- i. Mineral Soil Wetlands:

- **Marsh** – a type of wetland ecosystem characterized by poorly drained mineral soils and by plant life dominated by grasses (see. Figures 2, 3 and 4). Marshes are common at the mouths of rivers, especially where extensive deltas have been built. The marsh plants slow down the flow of water and allow for the nutrient enriched sediments to be deposited, thus providing conditions for the further development of the marsh.



Figure 2: Marsh





Figure 3: Tidal marsh



Figure 4: Common Cattail

- **Swamp:** This is a wetland ecosystem characterized by mineral soils with poor drainage and by plant life dominated by trees. Swamps are found throughout the world, most often in low-lying regions (with poor drainage) next to rivers, which supply the swamp with water. Some swamps develop from marshes that slowly fill in, allowing trees and woody shrubs to grow.



Figure 5: Swamp

The dominant vegetation, therefore, distinguishes the two major types of mineral soil wetlands: grasses dominate marshes, while trees dominate swamps. Both marshes and swamps may be freshwater or saltwater.

#### ii Organic Soil Wetlands:

Generally, these wetlands are referred to as "peatlands" in recognition of their common ability to form peat (organic soil produced by the accumulation of plant material). There are two major types of peatlands – bogs and fens, both of which occur in similar climatic and geographic regions.

- **Bog:** This is a type of wetland ecosystem characterized by wet, spongy, poorly drained peaty soil, dominated by the growth of bog mosses, *Sphagnum*, and heaths, particularly *Chamaedaphne*. Bogs are usually acid areas, frequently surrounding a body of open water. Bogs receive water exclusively from rainfall.



Figure 6: Bog

- **Fen** – a type of wetland ecosystem characterized by peaty soil, dominated by grasslike plants, grasses, sedges, and reeds (see Fig. 8). Fens are alkaline rather than acid areas, receiving water mostly from surface and groundwater sources.



Figure 7: Fen

## 5.2 Estuaries

Although the definition of an estuary varies considerably, in the simplest terms, it is a partially enclosed, coastal, brackish water body. It has a free link to the open sea and receives freshwater from one or more rivers or streams flowing into it. The dynamic system of an estuary is subject to fluctuations in the water volume, depth, salinity levels, etc.

## **A) Types of Estuaries Based on Geomorphology**

### **Bar-Built or Lagoon-Type Estuaries**

This type of estuary usually forms in tropical and sub-tropical locations. They are common near the tectonically stable continental edges or coasts of marginal seas. A lagoon-type estuary forms when the deposition of sediments forming barrier beaches partially cuts off a section of the sea water along the coast. Such barriers have one or more narrow inlets through which water exchange between the sea and the estuary takes place. Since barrier beaches mostly form parallel to the coast, the estuary formed by them tends to be long and narrow. The depth of such estuaries is generally lower than 16 ft.

### **Drowned River Valleys**

Drowned river valley estuaries are common in areas with a temperate climate. They arise by the penetration of seawater into land and the subsequent occupation of coastal river valleys by the sea. These estuaries are usually wedge-shaped. As the distance from the sea reduces, the estuary widens and deepens. However, the depths of these estuaries rarely exceed 100 ft. With climate change-induced sea-level rise, the number of drowned river valley estuaries is expected to rise in the future.

### **Fjord-Type Estuary**

A fjord-type estuary forms in river valleys widened and deepened by glaciers. Such valleys are U-shaped. Sills, rocks, or bars formed by centuries of glacial depositional activities at the mouths of river valleys partially blocks the flow of water into the sea. Such estuaries are flanked by steep slopes on either side. They are also very deep but the depth reduces seaward. Upstream, these estuaries can be more than 1,000 feet deep. The deep waters of these estuaries usually remain undisturbed as the sills or submerged reefs between the sea and the estuary prevents the free flow of water at greater depths. During heavy storms, however, the deep waters of the fjord-type estuary might be displaced.

### **Tectonically Produced Estuaries**

Tectonically produced estuaries are less common than other types of estuaries mentioned above. The formation of such estuaries happens due to the subsidence of land or increase in sea-level due to tectonic movements. Earthquakes, volcanic eruptions, and resulting landslides can lead to the formation of tectonically produced estuaries. Seawater inundation of the basin or depression created due to the tectonic movements or the rise in sea level due to such movements forms these estuaries. The San Francisco Bay is one such estuary.

## **B) Types Of Estuaries Based On The Circulation Of Water**

### **Salt Wedge**

When the flow volume and velocity of the river draining into the sea exceeds that of the tidal forces of the sea, the effect of tidal actions on the estuary is reduced to a minimum. In estuaries formed at such river-sea interface, the river water floats above the seawater. The latter moves inward in a wedge shape. The layer of seawater thins out as it moves towards land. A difference in the velocity of water at the freshwater-seawater interface gives birth to internal waves resulting in limited intermixing of the waters.

#### **Partially Mixed Estuary/Slightly Stratified Estuary**

In a partially mixed estuary, the force of tides is moderately higher than the river output so that significant turbulence is created in the waters of the estuary. Thus, seawater and freshwater mix moderately and salinity varies little vertically. However, salinity decreases with distance from the sea.

#### **Well Mixed Estuary/Vertically Mixed Estuary**

In this type of estuary, the mixing forces generated by the tidal action well exceed the output of rivers. Thus, intense turbulence is generated that mixes the estuarine waters well so that the vertical gradient ceases to exist completely. Thus, in such estuaries, the salinity of the waters is the same near the surface and at the bottom. The salinity level, however, decreases with increasing distance from the sea.

#### **Inverse Estuary**

In an inverse estuary, the salinity level of the estuary is higher than that in the open sea. Such estuaries are found in areas with an arid climate. When the rate of freshwater supply of the river forming the estuary is lower than the rate of evaporation of the water, little freshwater mixes into the estuary so that it becomes highly saline.

#### **Intermittent Estuary**

The salinity level of an intermittent estuary varies widely due to constant fluctuations in the supply of freshwater to the estuary.

### **5.3 WETLAND HYDROLOGY**

The world wetlands are playing a potential role in economic and ecological point of view. Particular interest has been shown to a number of wetlands around the world with regard to their extent uniqueness and attributes. It includes coastal and inland deltas, riverine wetlands, salt marshes and mangroves, freshwater marshes, and peatlands. They are found on every continent except Antarctica and in very rough climates from the tropics to the tundra. Wetlands in different parts of the world have a great importance for the country's economic, industrial, ecological, socioeconomic, and cultural context for certain reasons. They contain very rich components of

biodiversity of all valuable ecosystems. This ecosystem serves as habitat for a variety of resident and migratory waterfowl and endangered and commercially important species of national and international interest. Moreover, it supports a rich biodiversity of flora and fauna, substantially contributing to socioeconomic improvement for millions of people living especially in rural areas. This created livelihood sustainability is providing opportunities for employment, food and nutrition, fuel, fodder, transportation, and irrigation. Furthermore, wetlands are recognized as a driving force for biodiversity conservation and rural socioeconomic improvement. The smart use of wetlands can solve the ecosystem problems in the floodplain areas.

### 5.3.1 Hydrology of the Wetland

Hydrologic processes occurring in wetlands are the same processes that occur outside of wetlands and collectively are referred to as the hydrologic cycle. Major components of the hydrologic cycle are precipitation, surface water flow, groundwater flow, and evapotranspiration (ET). Wetlands and uplands continually receive or lose water through exchange with the atmosphere streams and groundwater. Water supply is necessary for the existence of wetlands. The wetland water budget is the total inflows and outflows of water from a wetland. The functions, persistence, and size of wetlands are controlled by hydrologic processes. Wetlands constitute a part of human heritage. It has played a significant role in the development of human culture and society. Moreover, it contains very rich components of biodiversity of local, national, and regional significance. They also provide a habitat for a variety of resident and migratory waterfowl, a significant number of endangered species, and a large number of commercially important species. However, high population density has resulted in intense pressure on both land and water resources.

### 5.4 Flood and Erosion

The earth's surface where human beings live is an arena of two antagonistic groups of forces whose interaction mostly determines the appearance of our planet. The energy of the processes within the Earth causes uplifting of the earth's crust, formation of ranges, volcanic cones and plateaus, and deformation of the earth's surface during earthquakes in many areas of the world. The processes within the earth, which are called endogenous, constantly tend to maintain and enhance topographic contrasts on the earth's surface. On the other hand, the solar energy and gravitation drive continuous mechanical and chemical weathering of rocks and leveling the earth's surface in a futile attempt to attain equilibrium. These processes, called exogenous, break down rocks, transport them by water or moving ice, accumulate rocky material at lower elevations, transport fine particles by air, wear away and build up the shores of seas, oceans and other large water bodies. While the two groups of processes are permanently in conflict, the domination of exogenous processes results in gradual reduction of absolute and relative heights of terrain, and general leveling the land. The exogenous processes are able to change mountains into rolling lowland a peneplain. On the other hand, in wet areas with intensive uplifting and high carrying capacity of running water, highly dissected topography with contrasting relative



heights is created. All processes of breaking down and washing out of bedrock, and removal of loose material to lower places, are called denudation (from the Latin *denudatio*). The main driving force of most denudational processes is gravity, which manifests itself directly (e.g. by rockfall and landslides in mountains) or through the movement of other media (water, ice, air). The driving process of denudation is water erosion, which greatly transforms the earth's surface.

#### 5.4.1 Water Erosion

Water running over the land surface breaks rocks down, carries away loose material, and transports it downstream. At lower levels, where the carrying capacity of streams is reduced or where a stream flows into a lake or the ocean, loose material deposits or redeposits. Every year streams carry about 17.0 billion tons of eroded material from the land to the oceans, seas, or large deep lakes. Rivers and groundwater that directly discharge into the oceans carry about 3.5 billion tons more. Other denudational processes, such as wind and glaciers, in total carry only about 3 billion tons from the land to the oceans. Rivers are of particular importance in the drainage network. These long-lived flows of water cross the greater parts of the continents. As they run, they cut into the earth's surface, creating valleys, and transporting a large amount of eroded material from the drainage basin. By deepening valleys, they enhance topographic contrasts, making slopes steeper and thereby stimulating erosion on the slopes.

Water erosion is controlled by many physiographic, geologic, climatic, and other factors, such as topography, types and distribution of soils, vegetation cover, lithology, land use, etc. However, the intensity, duration, and ultimate effects of erosion are determined by the organization and energy of running water. Depending on these factors, all streams of the land can be classified into three basic hierarchically interacting groups:

- a. Overland or sheet flows of snowmelt or rainwater, running over slopes and removing topsoil.
- b. Ephemeral streams, running in gullies and removing soil.
- c. Perennial rivers, flowing in definite channels, sometimes deeply cut into bedrock.

Overland or sheet flows are formed on slopes while water runs as a film, combined with water streams flowing in small channels. Running water carries away small particles of loose material, detaching them from soil aggregates and the packed upper layer of the soil.

If soil is bare or covered by sparse vegetation, raindrops facilitate the removal of mineral soil particles by run-off waters. While falling onto wet soil, a raindrop is reflected from it as a crown-like splash. Soil particles trapped by the splash are spattered from the place of the raindrop's landing. Soil particles are spattered downhill further than they are uphill. This difference is nearly threefold on a 10% slope.

Rainsplash or splash erosion prevails if soil-infiltrating capacity is high, being unfavourable for overland flow. The most intensive erosion occurs when thin sheet flow combines with falling

raindrops. The depth of overland flow has to be less than approximately three raindrop diameters. The arena of erosion caused by overland flow is a whole slope. The eroded material moves down the slope. Gullies can form in the middle or lower parts of a slope if the topography favours the concentration of overland flow and small streams. Their formation is preceded by the appearance of small depressions, rills, and trenches, which expand and join while eroding. A gully is a comparatively deep and narrow channel typically eroded by ephemeral streams or sometimes small perennial streams. Steep or even almost vertical slopes, V- or U-shaped cross-sections, and high branching are characteristic of gullies. They range from hundreds of meters to several kilometres long, and from several meters to some tens of meters wide, and are typically several meters deep.

Water-erosional landforms vary greatly. Thus, slope rills are only a few centimetres deep and wide, while large river valleys reach well into the tens of meters deep and are several hundreds of meters wide. Water-erosional landforms are generated under different conditions as a result of different driving processes. These are the criteria for the classification of spatial hydro-geomorphologic systems, which differ in geomorphologic structure and hydrologic functions. The generic types of water-erosional landforms do not strictly pertain to the appropriate types and hierarchic levels of hydro-geomorphologic systems. Hence typical sizes of water-erosional landforms are simply estimated to classify erosional landforms into a generic series.

### 5.3.2 Watershed Erosion

Water erosion on watershed slopes is a complex process that brings together the impact of raindrops, removal of slope deposits, and transportation of loose material by overland flow. Although the erosion activities of rain and overland flow are convenient to study separately, both these phenomena are closely interacting parts of the integrated process of water erosion. In general, water erosion on slopes is a result of interactions in the atmosphere, vegetation, soil, water system.

The intensity of water erosion naturally depends on two basic factors, i.e., the erodibility of surface deposits and the energy of water flows over the surface. These causes are controlled by a great number of factors, which together determine the readiness of surface deposits to be eroded and the ability of water flows to originate on slopes and to scour and transport loose material. There are very many combinations of these factors, which can induce or hinder erosion. In most settings, erosion in a watershed depends on the formation of overland flow.

### 5.3.3 Uniform Slope Site Erosion

Inclination, vegetation and soil within a small slope site can be considered uniform with the accuracy admissible for analysing erosion. The driving processes of the hydrological cycle of a site are vertical water flows such as atmospheric precipitation, infiltration, and evapotranspiration. A uniform slope site interacts with adjoining sites in a common water flow along the slope.



Under given climatic conditions, the formation of water flow in a uniform slope site depends on the infiltration rate of rainfall and the processes that affect the water-holding capacity of soil. High infiltrating capacity of soil decreases overland flow, and evapotranspiration between rains discharges soil capacity to hold more infiltrated rainwater. A slope site of low infiltration and low soil water-holding capacity is more suitable for the formation of water flow and hence erosion.

The rate of erosion, i.e., the amount of loose material removed from a slope site per unit of time, depends on the site slope, rate of weathering, grain size and petrographic composition of the deposition, and vegetation type, if other conditions are equal. The role of any factor in erosion is not constant. Moreover, the interaction between the factors of erosion rate is clearly nonlinear. This is generally illustrated in Figure 8.

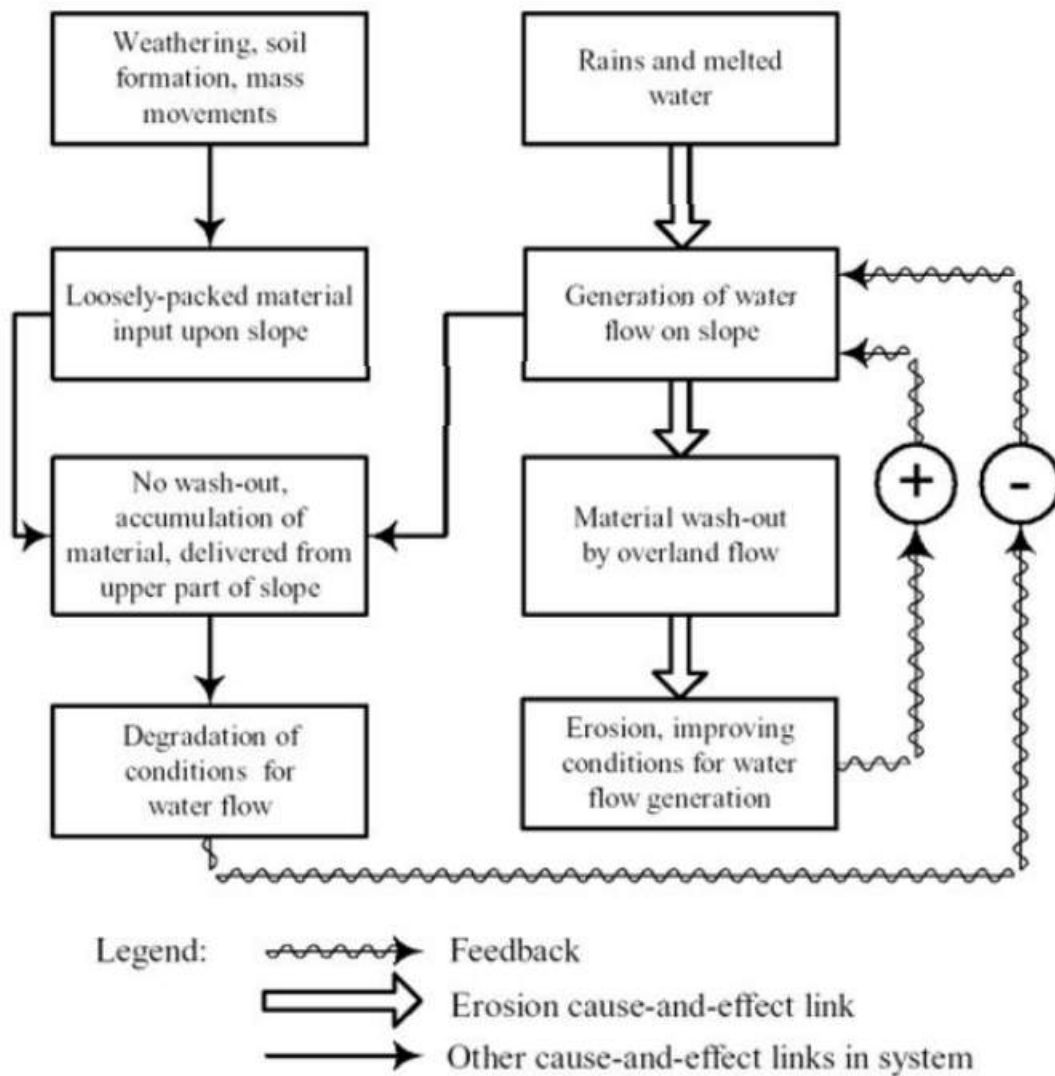

Figure 8: Feedback between overland flow and loose material wash-out in a uniform slope site

Bedrock weathering, soil formation, mass movement, and the input of material with overland flow from upper sites all contribute to the generation of loose material, which is subject to water erosion. Figure 8 shows the situation when the amount of erosion prone loose material decreases in a given site, i.e., the site is subject to erosion. It results in a reduction of the water-controlling capacity of the soil. This, in turn, intensifies runoff during rain, and increases the amount and energy of water flows. Hence positive feedback forms in the slope site system, reinforcing the input impulse, i.e., in this case the slope water flow.

When the balance of loose material on the slope becomes positive, it accumulates on the slope site. This results in an increase in rainwater held by the soil, and reduction of slope run-off and flow energy. These forms negative feedback in the hydro-geomorphologic system of a slope site (Figure 8), which reduces the erosivity of run-off and hence intensifies the accumulation of loose material.

The preceding only describes the most general relations of water and loose material in a uniform slope site. This pattern in nature is supplemented by the effects of many other factors, which may be short-term, seasonal, annual, or permanent. For instance, the active erosion phase can be changed into the stable phase, or even an accumulation phase, by the seasonal reduction of rainfall or gradual climate change toward aridity. Erosion is heavily controlled by vegetation, which protects topsoil from erosion, and prevents the impact of raindrops and formation of overland flow, and the density of vegetation varies through the seasons.

#### 5.3.4 Slope Erosion

A slope can be combination of two or more uniform sites combined by water flow parallel to the earth's surface. The hydro-erosion system of a slope is characterized by changing the inclination and the features or soil.

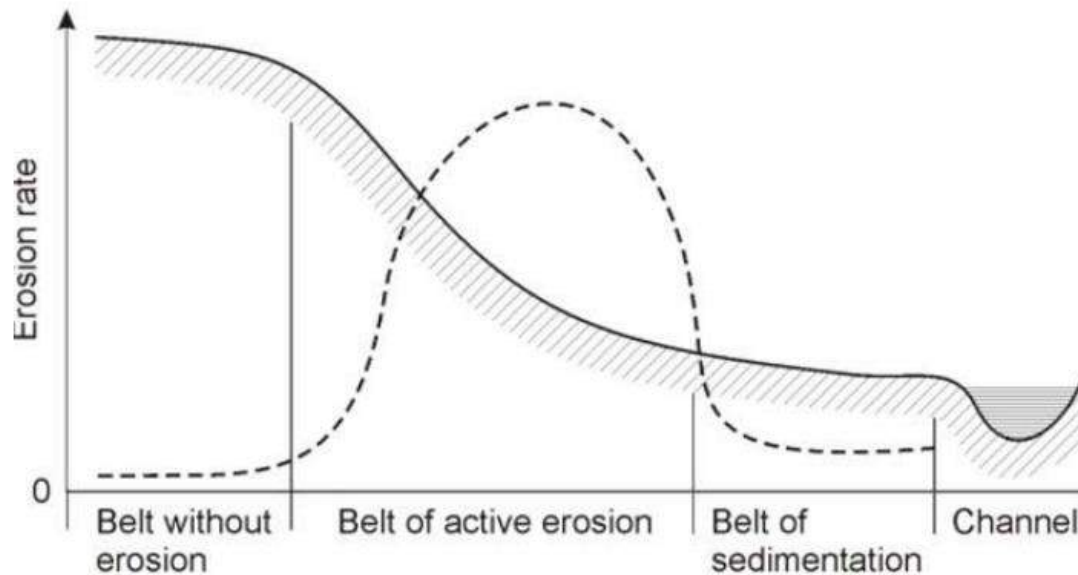

Figure 3. Erosion rate on a typical slope

Figure 9: Erosion Rate on a Typical Slope

If we consider a slope as a whole, erosion at any point depends on the ratio between soil erodibility and the energy of water flow. Soil erodibility is controlled by factors, such as soil moisture, clay mineralogy, organic matter, and permeability. Soil erosion resistance is enhanced by vegetation and build-up of compacted organic material. Soil erodibility depends more on the physical features and biological material (roots, soil colloids, organic and mineral aggregates, etc.) of topsoil than the structure of the lower layers of the soil profile. The erosivity of a slope water flow depends on its flow energy, which is proportional to the volume of water and the speed of run-off. These values are controlled by the location of a site on the slope and its inclination. Hence the upper, middle, and lower parts of a typical slope of a watershed are characterized by different erosion rates (Figure 9).

Water erosion is not common in the upper part of a slope because of the low energy of water flow. This is why the upper part of a slope is sometimes called the belt without erosion. The water-holding capacity of soil and loss material depends on chance combination of factors such as parent rocks, their weathering, and soil formation.

The middle part of a slope is characterized by higher propensity to generate powerful water flow, and water erosion and the removal of loose material is most active here. This part of slope is usually called the belt of active erosion.

### 5.3.5 CATCHMENT CONCEPT

The word catchment is used interchangeably with watershed. Watershed or a catchment is an isolated area with a well demarcated boundary line, draining the rainwater to a single outlet. Within the boundary a watershed contains various natural resources such as the soil, water and natural vegetations. Also, there is a network of stream system to drain the rainwater. The stream network is also called drainage system of watershed. A watershed having the measured hydrological parameters such as rainfall, runoff and others is called gauged watershed. For hydrological study of watershed, the hydrological input data is essential. There is a variation in one to other watersheds regarding shape, size, morphology and other aspects. This variation enforces to cause variations in rainfall-runoff, soil erosion/loss relationship. The stream network system makes the watershed dynamic in regard to hydrologic processes. View of watershed is shown in Figure 4.



Figure 4: Graphical Representation of Watershed

### 5.3.5 Watershed Component

The followings are the major components of the watershed,

1. Watershed boundary,
2. Stream network,
3. Watershed soils/land, and

#### 4. Land use system.

**Boundary-** It defines the size and shape of watershed. Boundary of a watershed may be the any continuously elevated ridge lines covering a particular extent of land segment. Also, the river line, roads, etc may be as the watershed boundary.

**Stream Network-** The watershed within its boundary assembles several interconnected streams leading to the outlet. Stream network constitutes drainage system for the watershed.

Drainage system is assessed by the term called drainage density, which is defined as the ratio of total length of streams to the total area of watershed. A watershed with high drainage density is highly drained and vice-versa. In addition, the stream frequency which is the ratio of total number of streams to the area of watershed also signifies the degree of watershed drainage.

**Soil-** There is possibility of a large variation in occurrence of soil in respect to its type, geography/topography etc in the watershed. Availability of good and healthy soil makes the watershed more productive which forces the population to a good level with their high standard of living. In hilly watersheds, however, the availability of land for cultivation is very limited, normally located at the riverbed and few at the slope faces, which may be under constraint of high slope. The soils at steep slopes cannot be directly used because of problems in use of tillage or cultural practices for crop growing. Normally, such steep lands are converted into terraces of different types depending on the soil types and rainfall of the area for cultivating the crops.

**Land use-** Mainly, the land use system comprises, agricultural, orchard, forest land, grassland/pasture and waste land uses. The waste land use may be with vegetation or without vegetation. Land use system affects the hydrological behaviour of watershed. For example, a watershed dominated by the forest land use system involves very less runoff or rainwater availability for harvesting point of view than another watershed which involves very less extent of forest lands. To a large extent the land use system maintains the watershed towards its management aspects.

**Watershed Morphology-** It includes overall surface characteristics of watershed including the stream network comprising the stream ordering, stream length, stream slope, areal aspect, relief aspects etc mainly. Related to watershed morphology there are various laws defining the features of watershed; they are the law of stream order, law of stream length, law of stream slope, law of stream area etc.

**Stream order:** In order to facilitate the study of watershed behaviour on morphological aspects the stream ordering is followed as an approach for categorizing the streams into different orders as per their sequence of their origin. This also provides a basis for dividing the entire area of watershed for grouping, stream wise. There has been devised a rule for proving order to a given

stream of watershed. For stream ordering the watershed map containing the stream network is essential.